

Three Legged Stool

Drawing scale / size:	1:1 47-1/2" X 34-1/2"
Drawn by:	Randy Cordle
Date:	January 01, 2016
File:	Bluestem Three Legged Stool 010116.dcd

This drawing provided by Bluestemstrings.com and may not be re-produced, copied, or used for any purpose other than individual use without the express written permission of the author.

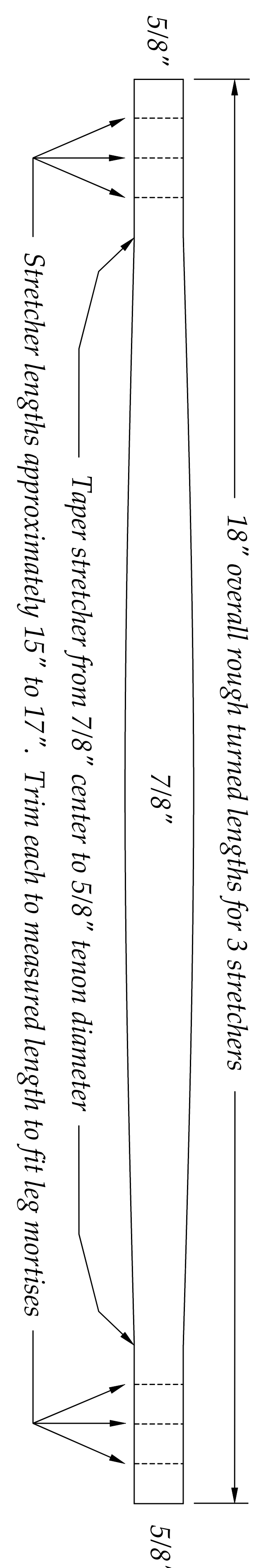
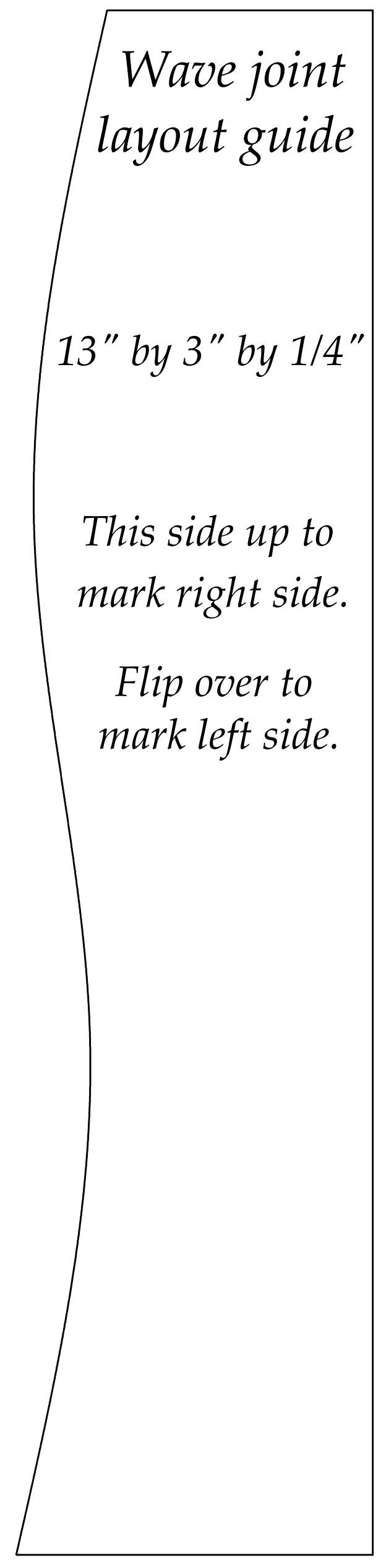
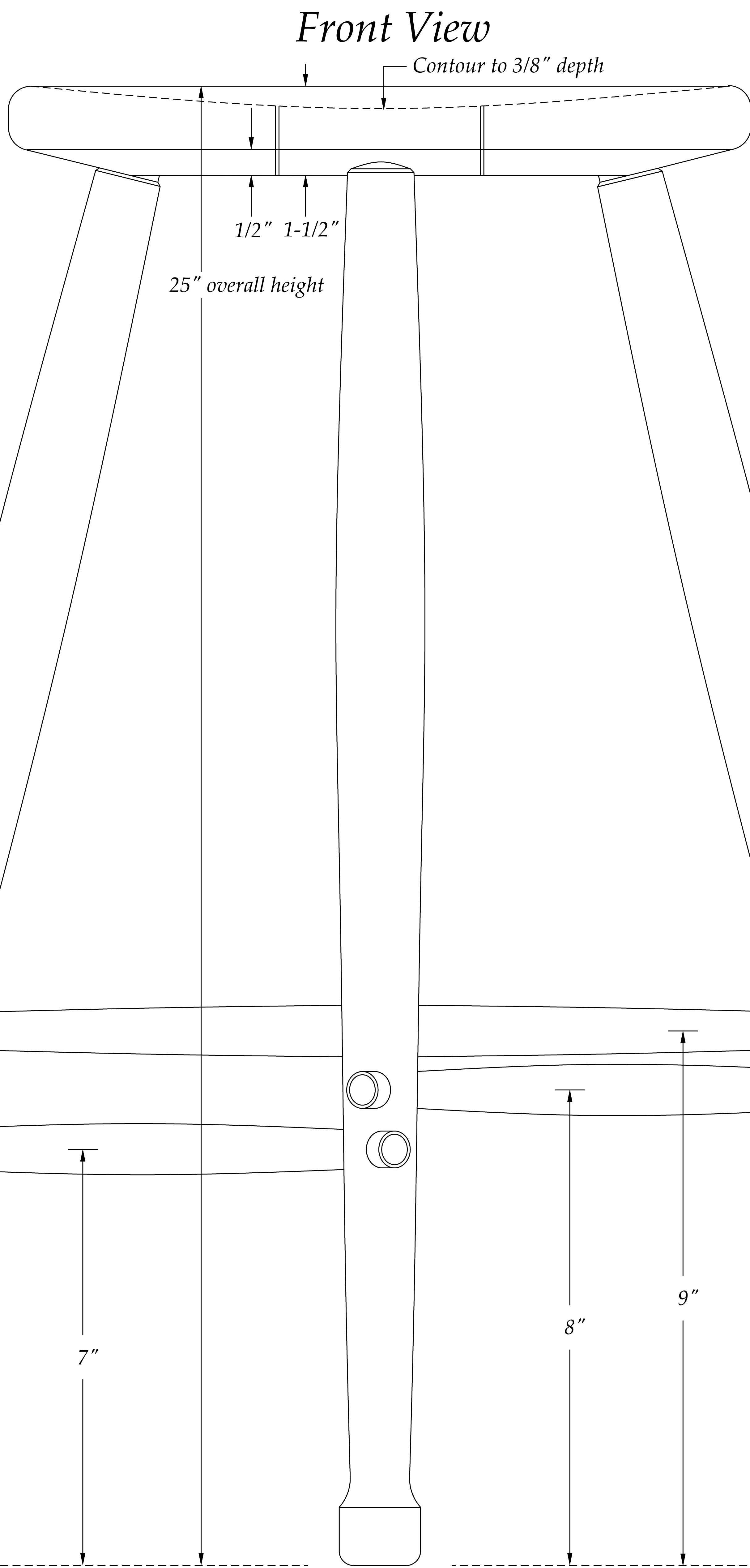
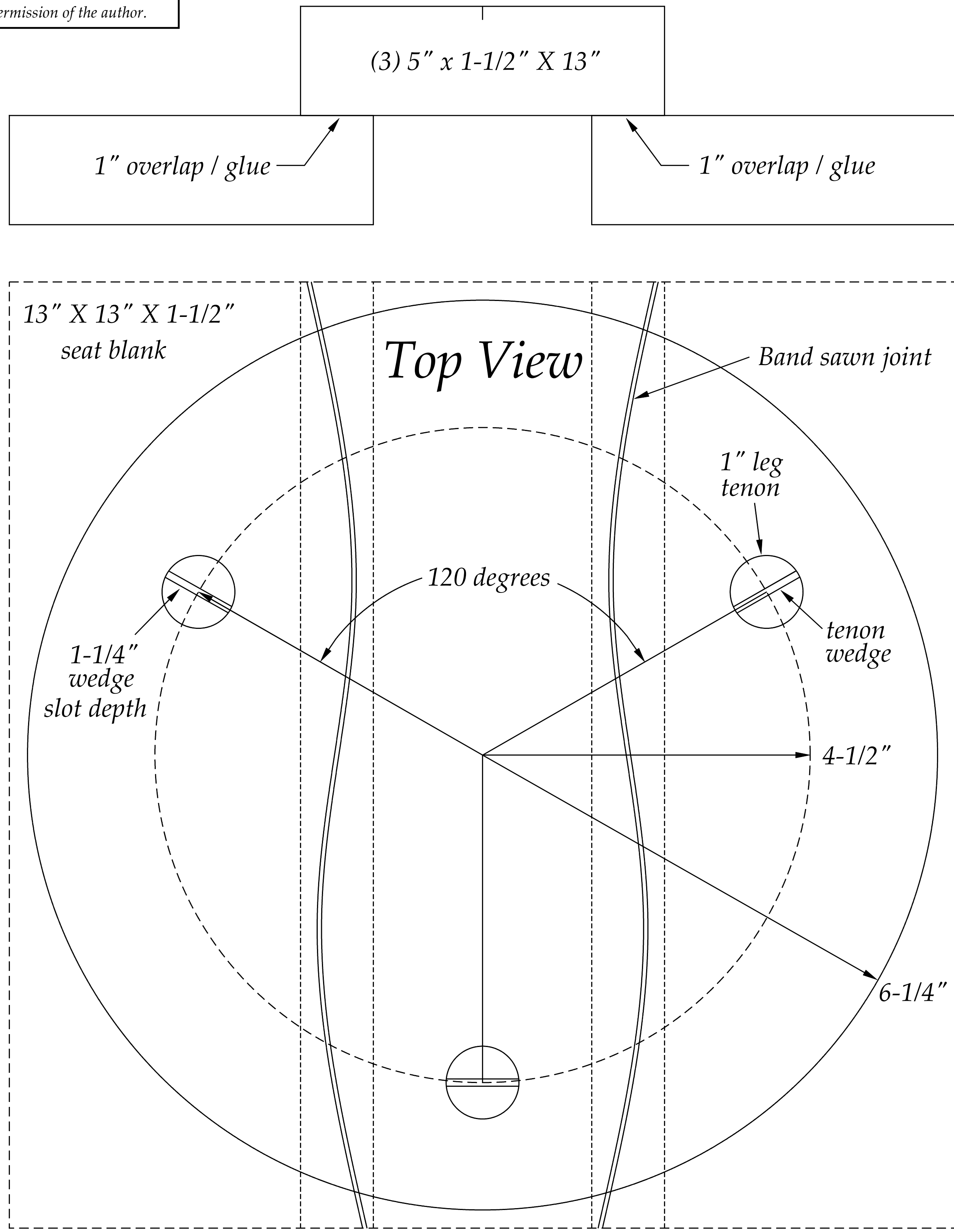

Leg Stretcher Detail

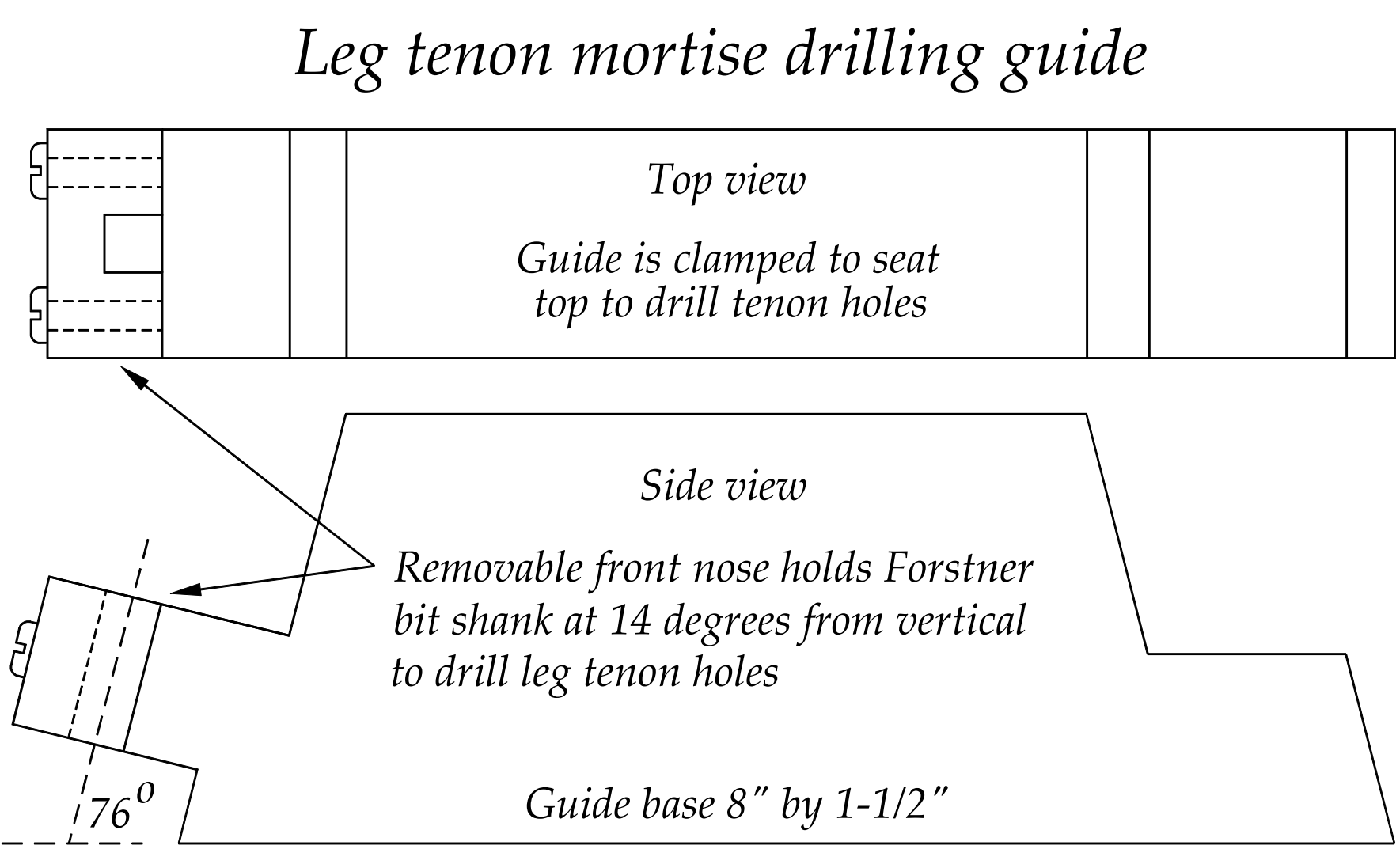

Notes

"Wave Joint" for seat is made by lightly gluing seat layers together, cutting layers apart with band saw and replacing the kerf width with contrasting wood filler strip, resulting in a flawless and unique glued seat joint.

Stretcher ends appear to pass through the legs, accomplished by housing the stretcher ends in shallow tenon mortises.

Stretchers are anchored by using glue and 2" by #8 drywall screws.

Shallow tenon mortises are added to the outer side of the legs in line with the stretcher ends to house short "faux tenon ends" to cover the screw heads used to secure them.

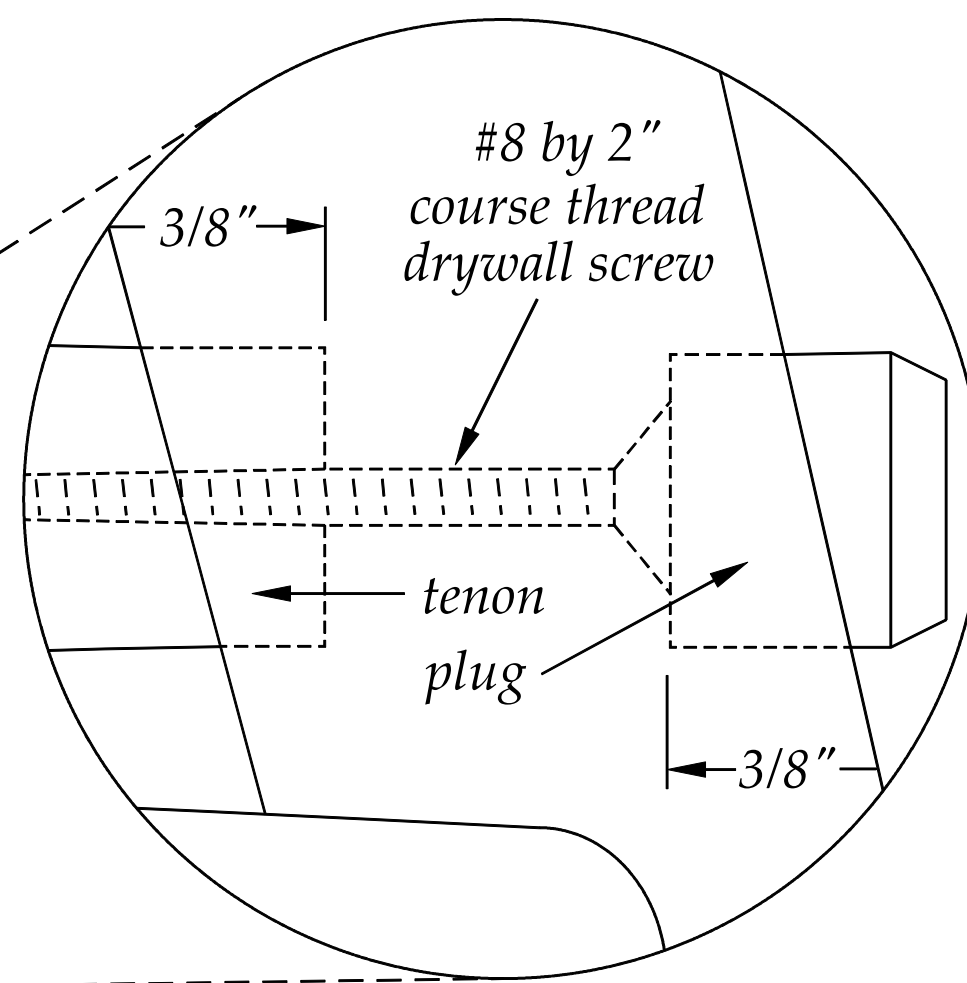

Tenon sizing gages

Drill 5/8" and 1" holes in 3/4" thick stock and cut to bisect the drilled holes.

Wedge cutting jig for leg tenon

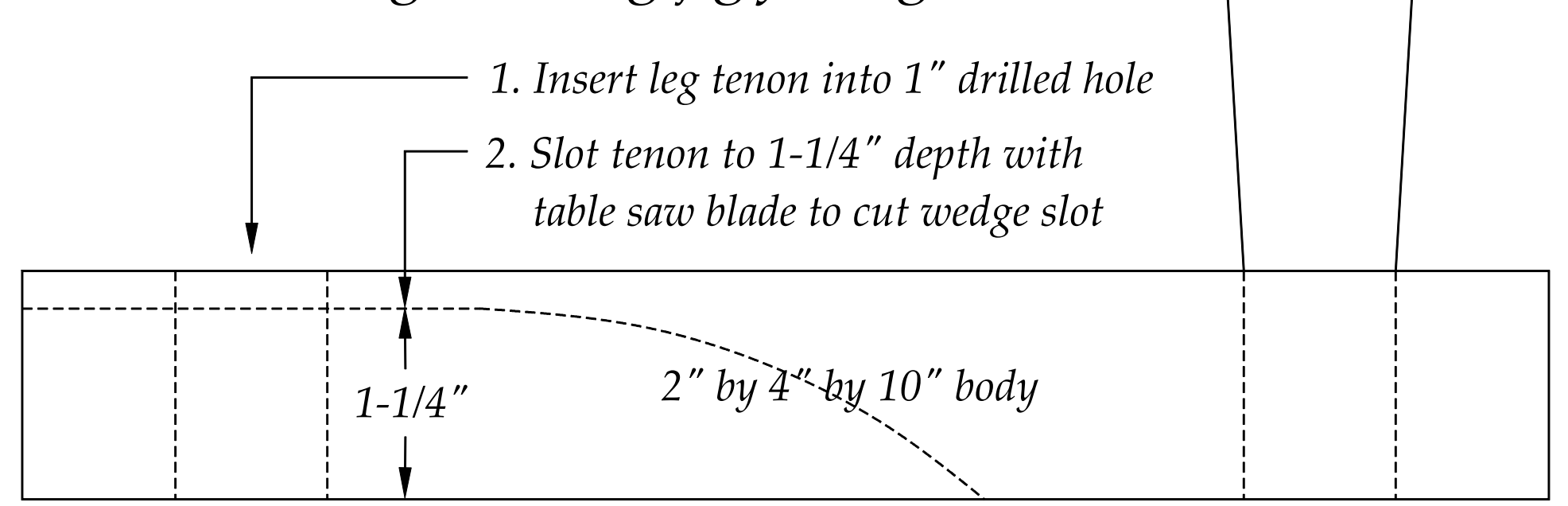

Leg Turning Details: Lengths, diameters, and rounding

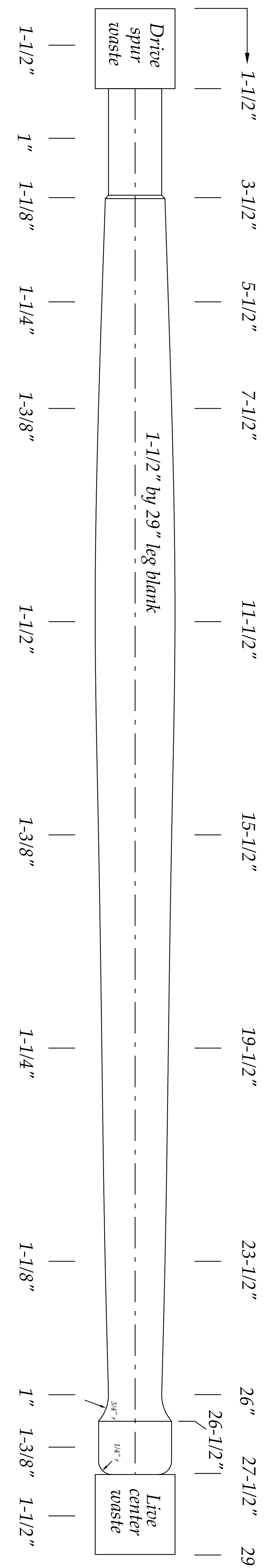

Gage Blocks

Use to transfer stretcher locations to legs.

