

BENCHCRAFTED CLASSIC LEG VISE

Assembly and Installation Instructions

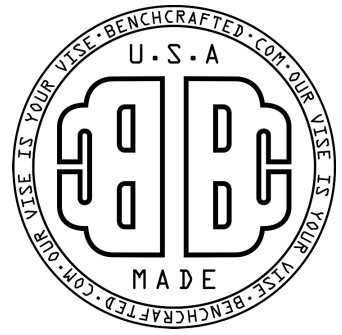

Version Jan. 2022

Package Contents

Classic Leg Vise

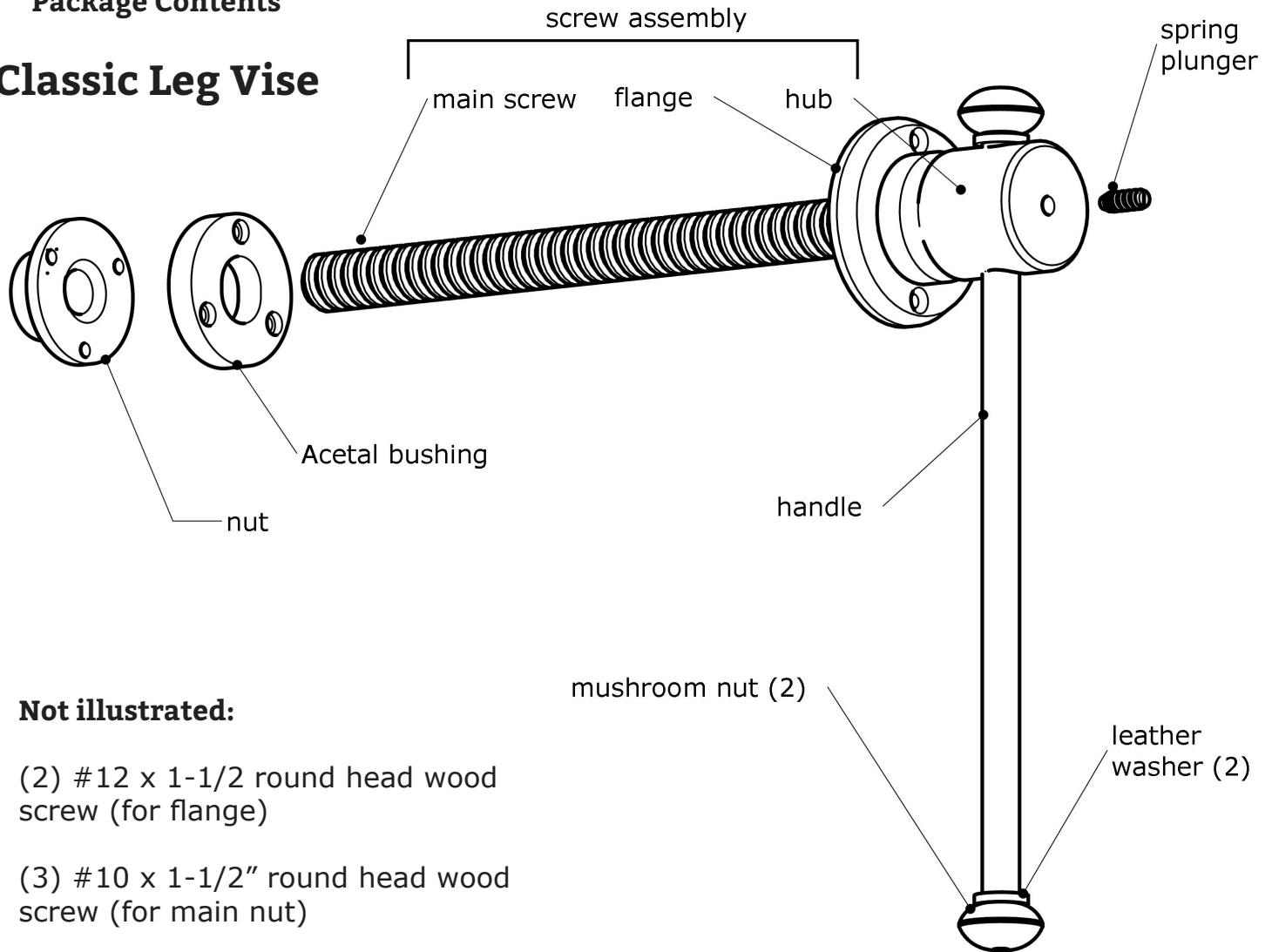

Not illustrated:

(2) #12 x 1-1/2 round head wood screw (for flange)

(3) #10 x 1-1/2" round head wood screw (for main nut)

(3) #8 x 1-1/2" round head wood screw (for acetal bushing)

(2) 3/16" x 1-1/4" groove pin (disregard if your vise hub, flange and screw are already assembled)

(2) pieces of Crubber

Package Contents
with Crisscross Solo

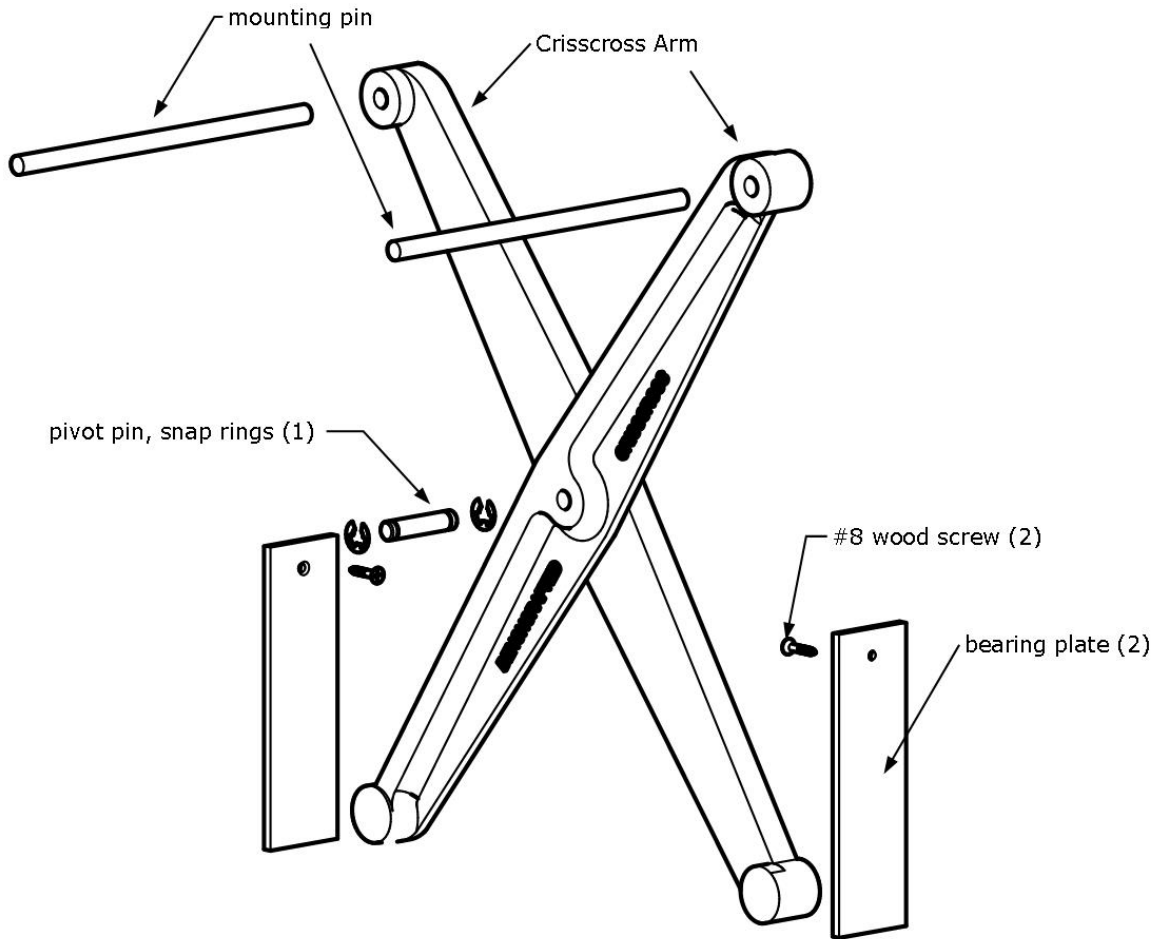

Hardware pouch contains 3 snap rings, we include an extra in case you should loose one.

IMPORTANT NOTE ABOUT CRUBBER

Effective September 2021

Due to raw material shortages, Crubber availability is sporadic, so during this time we sometimes substitute suede leather for Crubber depending on availability. Thus, your vise may include suede leather instead of Crubber.

If you received suede with your vise, it can be installed in exactly the same way as the Crubber, using the same glues. Any mention of Crubber in these instructions applies directly to suede, whether it be in installation method or function.

! READ ME FIRST !

Read and understand these instructions ***completely and thoroughly*** before starting the installation or cutting into your bench project. Only begin installation once you have the hardware in your shop. There are variables explained throughout the installation process that will affect the first steps of the install. It's important that you ***read through the instructions from beginning to end before you begin*** to have a successful install.

UNPACKING THE COMPONENTS

Some parts are heavy. Be careful as you unpack and handle them. Also be aware that although we make every effort to ease all edges, you may encounter a sharp edge or burr. If you do, ease it with some fine abrasive paper or a fine file. Some components may have a rust preventative oil applied. You may want to remove this oil before installing the vise. Wipe it off with a paper towel. This will leave a light film of oil on the parts that will help prevent rust and keep the parts moving smoothly. You may find a slight excess of powder coating in the 3/8" holes in the Crisscross arms and Retro brackets, making the mounting pins a little difficult to insert. Simply run a 3/8" twist bit at slow speed in a hand drill through the holes to clear any excess coating.

ASSEMBLY

Your vise hub, flange and main screw may already be assembled. If so, skip this section.

To assemble your vise you'll need the hub, flange, main screw and the groove pin from the hardware kit. You'll need a small hammer and a 1/8" pin punch. These are commonly available at any hardware store. Slide the flange onto the shaft of the screw. The flat side faces the screw threads (the concave side mates with the back of the rounded hub.) Now place the hub onto the screw shaft. The fit is precise, so don't force it if you feel resistance, simply rotate the two parts in your hand, keeping them straight

to each other until they slide together. If it doesn't go, look for burrs on the hub or screw. You can create a burr if you hit the hub or screw against each other while unpacking the vise.

Look into the 3/16" cross hole in the hub and rotate the screw until you see it line up with the hole in the shaft. The screw has two holes in the shaft (the hole closer to the screw threads is for our Glide leg vise) it will be readily apparent that you'll use the hole that's closer to the end of the shaft since the other one will be impossible to line up. Now insert the groove pin into the hub, smooth end first. It will slide in freely until it contacts the shaft. Now rotate the shaft slightly until the pin drops into the hole in the shaft. When

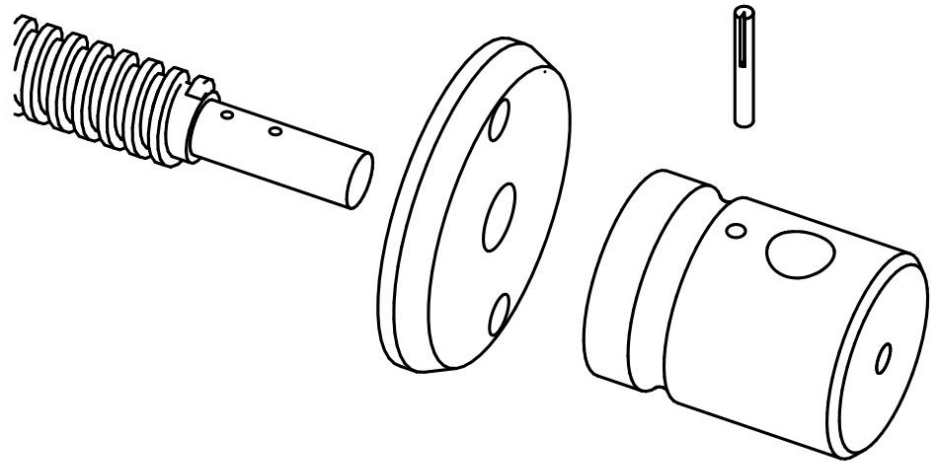

the groove in the end of the pin meets the outside of the hub, begin tapping on the pin with your hammer until it begins to tighten up in the hub. When tapping the pin into the hub, you should use a block of hardwood to raise up the hub so its supported firmly under your hammer taps, instead of resting on the flange's edge. Once the pin is tapped nearly fully into the hub, use the punch or nail set to finish driving the pin into the hub. Tap the pin until its centered in the hub. Look from both sides of the hub. It's very important that the pin be centered. If it's not, you can shear the pin off with the action of the vise. The vise is now assembled. The flange should spin freely on the shaft.

INSTALLING THE CLASSIC LEG VISE WITH A CRISSCROSS

These instructions cover installation of the Classic Leg Vise with a Benchcrafted Crisscross Solo or Retro. The first step is to install the Crisscross, then the Classic Leg Vise. These instructions follow that order.

If you're using a Crisscross 14 with your Classic Leg Vise please follow those instructions (available at Benchcrafted.com) then come back here to finish the Classic Leg Vise installation on page 20.

CRISSCROSS SOLO VERSUS CRISSCROSS RETRO

We designed the Crisscross for new bench construction and named it the Crisscross Solo. Soon after we discovered it would be difficult to drill the deep hole for the Solo's mounting pin in a leg that was part of an already assembled workbench. So we designed and manufactured special brackets so the Crisscross could be more easily "retrofit" into an existing bench without drilling those deep holes. We call this version the Crisscross Retro. Many bench builders prefer to install the Crisscross Retro, even in new benches because they prefer the installation method. The Solo is recommended for new benches only, the Retro for both existing benches or new benches.

HOW THE CRISSCROSS ARMS ASSEMBLE

The two arms join in the middle using the pivot pin and two "snap" retaining rings. We include an extra retaining ring in the package because they are easy to loose. During installation, it's best to install just one retaining ring because you'll be removing the pin and separating the arms a few times during installation. You can install the second ring after the vise is completely installed. Make sure you orient the arms the correct way during the installation. The round bosses at the top of the arms should point away from each other. See illustration below.

Correct

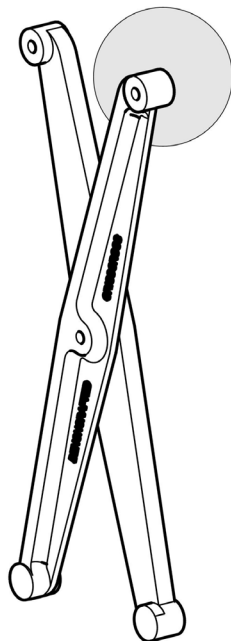

Incorrect

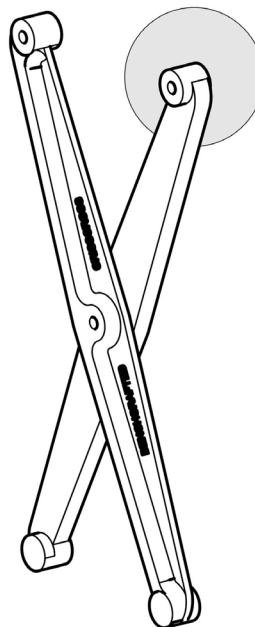

PLANNING YOUR INSTALL

In new installations where you're installing both the Classic Leg Vise and the Crisscross together in a new bench, simply follow the measured drawings at the end of these instructions to layout the holes and mortises as specified. The Crisscross, flange and nut will automatically be aligned if you follow the drawings and instructions.

If you're retrofitting your Classic Leg Vise to an existing bench and chop, see the drawings at the end of these instructions to make sure your leg and chop can accommodate the vise. If not, you may need to modify your leg and chop so the vise can be installed properly.

The Crisscross occupies 19-1/2" of vertical space in your bench leg and chop. You can position the Crisscross anywhere you like vertically (it should be centered left-to-right in the leg and chop, directly below the vise screw.) It's best to install the Crisscross in the lowest possible position on your bench leg. This allows you to also mount the vise screw in a lower position, giving you the greatest possible clamping capacity above the screw. Ideally, we like to keep about 1" of material below the Crisscross mortise at the bottom of the leg and chop, but if your situation dictates that your mortise be open all the way to the floor, this does not present a problem. The Crisscross will open to a maximum of about 16", but this is variable depending on the thickness of your chop and leg. You should not mount the Crisscross Solo in a bench leg that's narrower than 3", or the Retro in a leg narrower than 4". Your leg and chop each need to be at least 2-1/2" thick (you could go thinner, at your own risk.) You don't need thick stock, you can laminate 8/4 stock onto 4/4 stock to achieve that thickness. Position the glue lines towards the inside face so the mortise floor falls within solid stock (not on a glue line.) The chop can be as narrow as 5", but you'll get better grip if you make it up to 8" wide at the top. You can cut any design you like onto the sides of the chop--tombstone shape, coves and curves-whatever (the design we show here is just one possible shape) just save that step for the very end.

To layout the Crisscross mortises, refer to the measured drawings at the end of these instructions. It is not necessary for the Crisscross to be a specific distance below the vise screw, but you do need enough space for the acetal bushing. The location on the drawing is simply a lowest posi-

tion of both the Crisscross and vise screw together in a given bench height. You can shift both the Crisscross and your vise screw locations up or down to suit your bench (Dimension "X") Layout everything in full size before you cut anything.

Four points to consider when determining where to vertically position your Crisscross:

- 1. The space below the Crisscross mortise:** ideally, you don't want the mortise to be open at the bottom of the leg. Best to keep some material here. 1" minimum. Although if you have a wide and thick leg (5" or more) an open mortise won't pose any problems. Make sure you chamfer the end of the mortise so you don't blow out material if you drag your bench across the floor.
- 2. The distance between the top of the Crisscross mortise and the acetal bushing:** Leave a little material between the bushing and the mortise for strength. You can get a bit closer with the Solo. The drawings at the end of these instructions show the ideal distance below the acetal bushing.
- 3. Height of the bench:** If you have a tallish bench of 36" or so, you might want to move everything up a little. The drawings show, again, lowest possible position. This makes for a lot of room above the screw, but you might want to reduce this so you're not bending over too much to grab the vise handle.
- 4. Possible interference with an upper rail and/or the benchtop:** If you position your vise and Crisscross without regard to upper rails running between your front and rear legs, or the benchtop itself, you might find either part ending up where the vise's nut needs to be. This is especially important in very short benches. If you are retrofitting a Crisscross and have less than about 20" below the screw, you may need to move the entire vise up to accommodate the Crisscross. Again, layout in full size before cutting or drilling.

CUT MORTISES IN THE LEG AND CHOP

Once the location of the Crisscross has been determined for your leg and chop and all the layout work has been done, it's time to cut the mortises in the leg and chop to receive the Crisscross Solo or Retro.

Crisscross Solo only

First, drill the two 3/8" holes in the chop and leg for the mounting pins. Use a drill press for maximum accuracy. If you don't have a drill press or aren't confident drilling these deep holes, you should use the Retro version of the Crisscross (contact us if you'd like to buy Retro brackets for your Crisscross Solo, as they aren't available directly on the website)

Tip: when drilling deep holes use a sharp, high quality bit and back the bit out frequently to clear chips. Drill clear through the leg and chop to make installation easier should you need to tap the pins out from the opposite side. Don't try to meet in the middle by drilling from each side.

Crisscross Solo and Retro

Now cut the 1-7/16" deep mortises in the chop and leg. Note that the Retro mortises have a wider section at the top to accommodate the Retro brackets (see the dotted lines on the drawing.) The Solo mortise is just a long rectangle. We like to hog out most the waste on a drill press with a Forstner bit, then clean things up with a plunge router and edge guide. But a chisel can do the same work if you prefer.

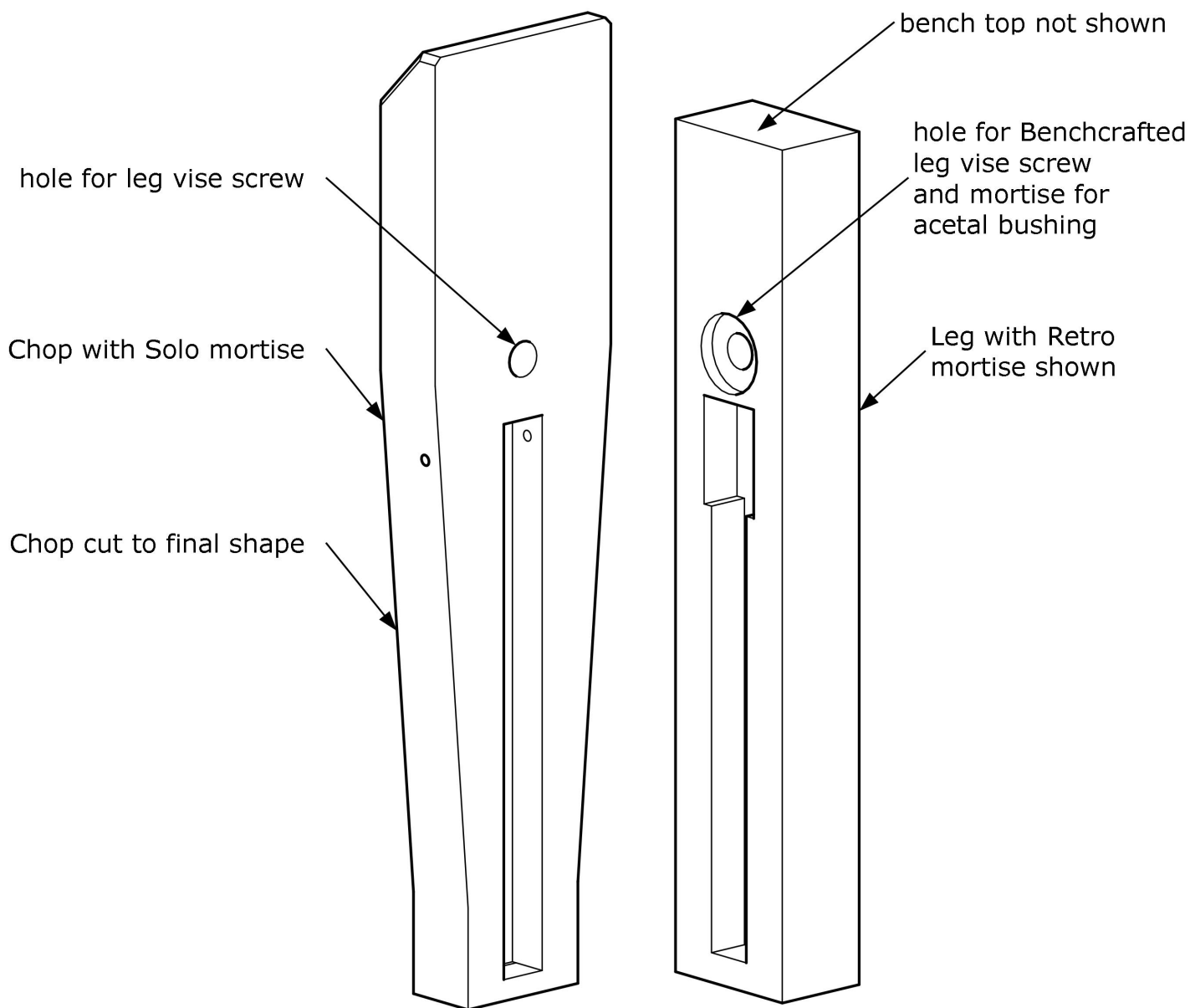

Above is an illustration of the mortise and mounting pin holes for the Crisscross Solo (illustrated on a chop) and the mortise for the Crisscross Retro (illustrated on a leg.) The holes and bushing counterbore for the Classic Leg Vise are also illustrated here for reference and throughout these instructions, although at this stage the holes are not yet drilled. The chop is also shown cut to final shape for illustrative purposes. Cut the final shape AFTER the vise is installed to completion.

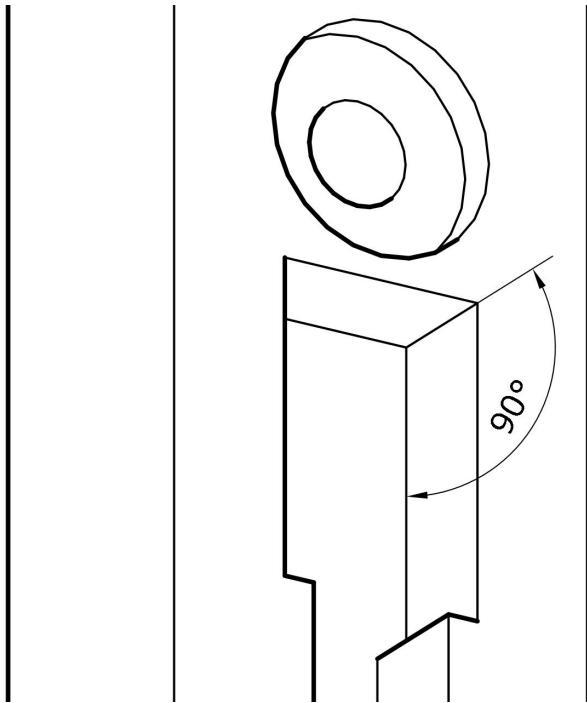

It's important that the back and top surface of the Retro mortise (where the machined surfaces of the bracket bear against) are perpendicular to each other. See illustration above.

Once the mortises are cut, install a bearing plate into the bottom of each mortise: one in the leg, and one in the chop. They DO NOT get mortises of their own, but simply surface mount to the back surface of the Crisscross mortise with the single screw.

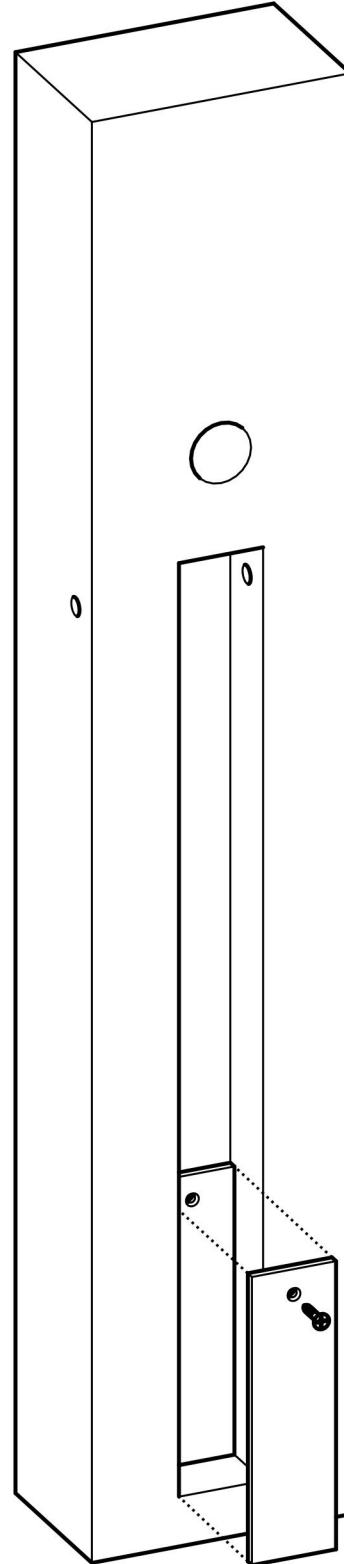

Crisscross Solo (skip ahead to Crisscross Retro section if you're installing the Retro version)

For this next step have the leg mounted rigidly to a workbench so you can test the action. It can be clamped with a long clamp to a benchtop, or held in a vise if you already have a workbench to use.

Now install the arms into the leg and chop by tapping the mounting pins into the holes until they poke through into the mortise a little. Slip each arm onto the pin and continue to drive the pin until it enters the opposite side about an inch. You don't need to drive it all the way through the leg at this time. Slide each arm on its mounting pins so its up against the mortise wall with the flat back facing center. Make sure you have them oriented correctly (see page 7.) Once the arms are installed, bring the chop to the leg, swing the arms together until the pivot holes line up, then insert the pivot pin (it should only have one snap ring on at this point.)

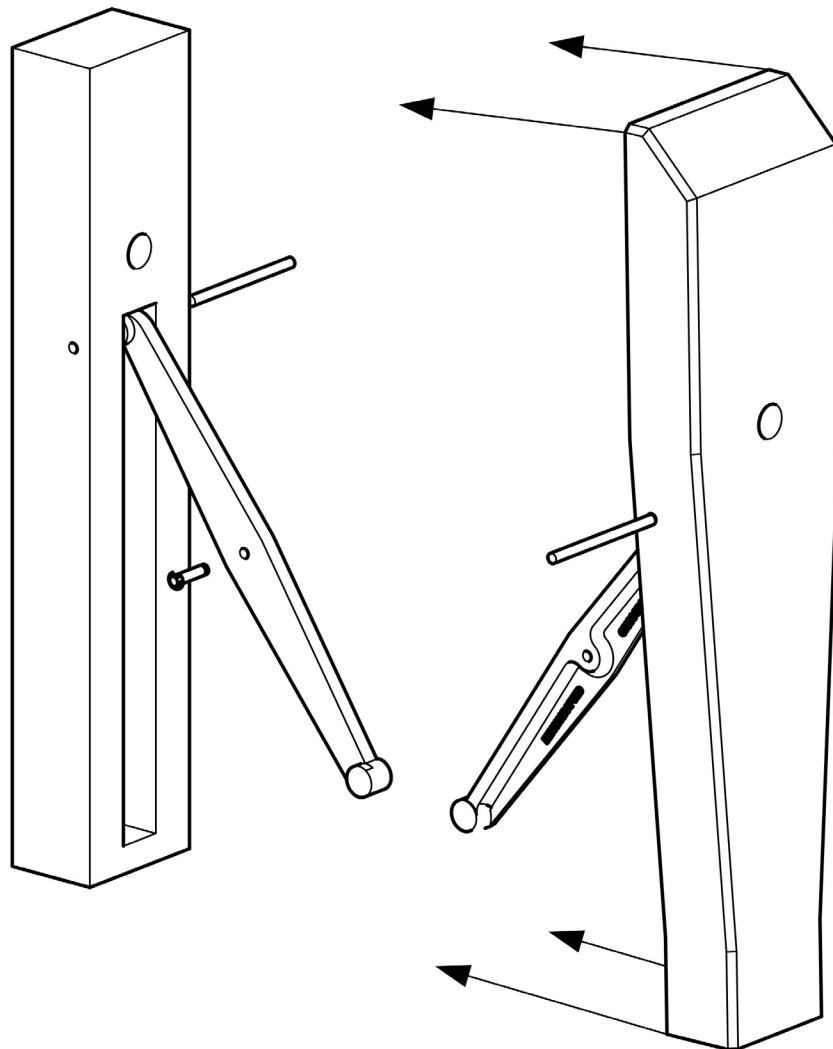

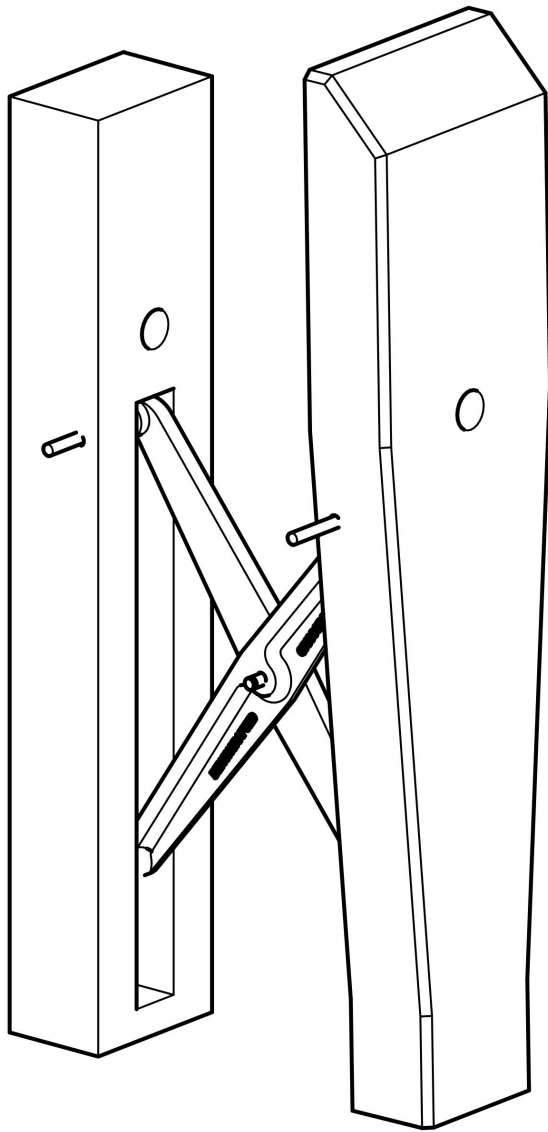

TEST THE ACTION

If you haven't already, clamp the leg upright in a vise or to a bench top so it's held securely. The chop should glide or "float" smoothly as you open and close the chop. If it doesn't, make sure the arms aren't rubbing tightly against wood in the sides of the mortise. The arms will generally find their own center after a short time.

CHECK THE TOE-IN

Toe-in is when the chop contacts the very top of the leg (or ultimately the top of the benchtop) first. You want some toe-in. It is essential for holding the work securely. If there is no toe-in (chop closes dead parallel to the leg), or negative toe-in (gap at the top) you should make some adjustments to get some toe-in.

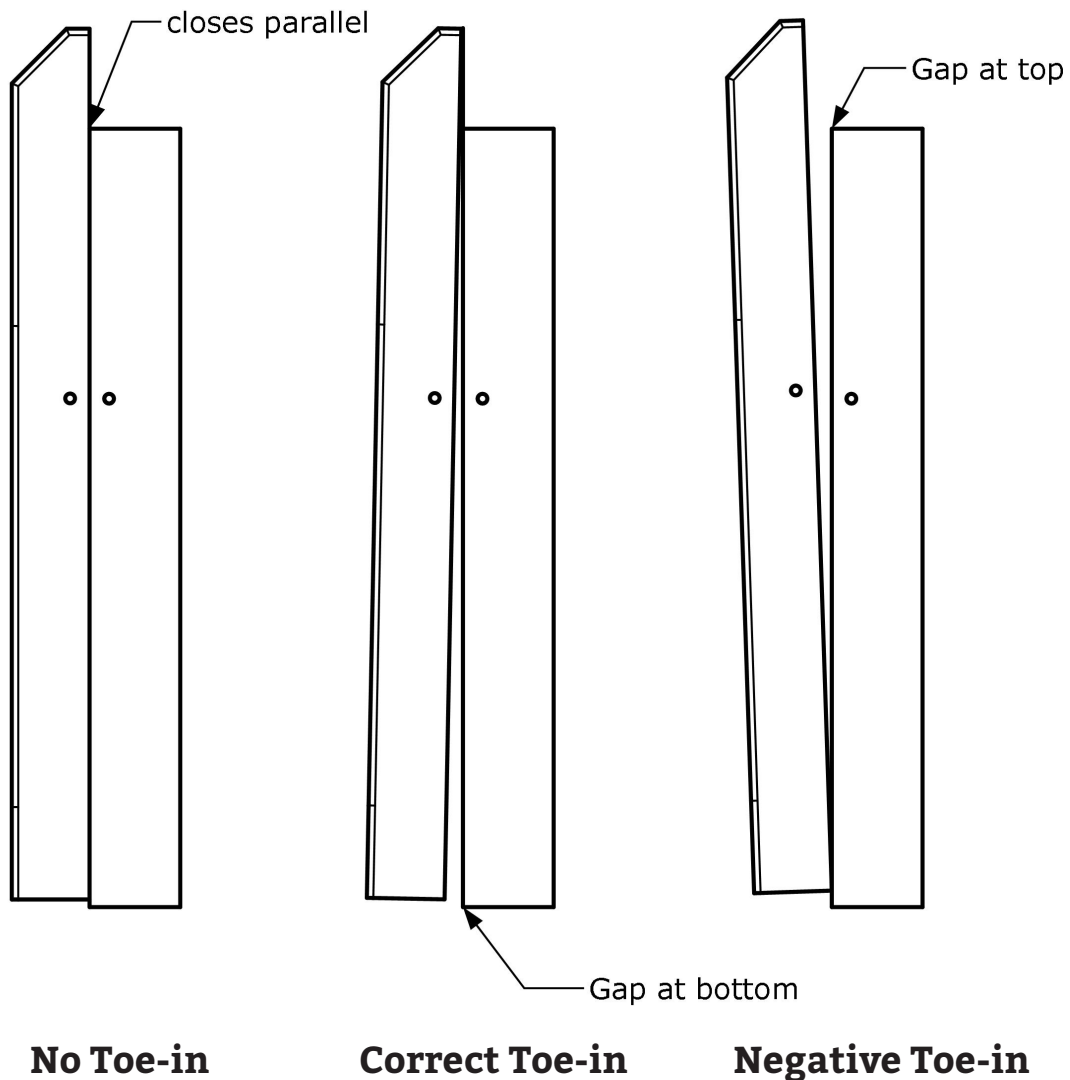

If you have too much toe-in, it can cause the screw's flange to bind on the shaft. To reduce the toe-in in this situation, you'll need to remove the bearing plate from the chop, then remove some wood from the mortise just behind the bearing plate area so the bearing plate sits deeper in the chop's mortise. Start off with making the mortise 1-1/2" deep behind the plate (so adding 1/16" to the normal depth.) Reassemble and evaluate. Go deeper if necessary. If you have no toe-in, remove the bearing plate in the chop and slip a piece of veneer, or some dense cardboard behind the plate, this will tilt the chop in and create some toe-in. If you have negative toe-in, the process is the same, add a shim behind the chop's bearing plate. If negative toe-in is excessive, you may have drilled your mounting holes too close to the inside faces of the vise. Plug the holes and/or reposition the Crisscross up or down (you'll have to adjust the mortise length too) so you can drill correctly positioned holes. These methods work for adjusting your toe-in, but they can all affect the smoothness of the vise's action, especially if you go too far with an ad-

justment. If you find you have zero or negative toe-in, but the vise is operating sweetly, the best course of action is to dismantle the vise and plane a taper onto the inside face of the chop so it contacts at the top first. This gives you the toe-in you're after without affecting the mechanical action of the vise.

There is no magic number for determining the gap at the bottom for correct toe-in. 1/4"-3/4" can work fine. If the jaw contacts first at the top, holds well, and the vise spins freely, you're good to go.

TIP: To remove a mounting pin during installation, use a smaller pin (we use a long phillips screwdriver) to tap it out. The smaller pin will catch the hole in the Crisscross and keep the arm engaged with the chop/leg. You can now pull the smaller pin out easily since it's loose in the hole and safely remove the Crisscross arm from the mortise.

Now you can cut the mounting pins to final length and smooth the ends for a finished look. We like to chuck the pins in a drill and run the ends against a piece of sandpaper. Next, install the Classic Leg Vise. Instructions are a few pages ahead.

Crisscross Retro

For this next step it's handy to have the leg and chop flat on your benchtop or worksurface.

Place a bracket in the mortise and press it tight to the upper end of the mortise (where it butts into end grain) and while holding it tight, use a transfer punch or awl to mark for the two mounting screws. Try to bias the location slightly towards the upper end of the hole in the bracket, so as you install the screws the bracket will be drawn tight to the upper end of the mortise. (see illustration on next page) You can see why its important to layout your mortise carefully, since the end of the mortise here, where you chopped it square, determines the vertical position of the Crisscross and the alignment of the arms to each other. Be diligent to get everything correct here. Take your time and work with care and attention. Drill and tap for the 5/16"-18 mounting screws. (See the addendum at the end for info on tapping wood for machine screws)

Then test mount both brackets in the leg and chop by turning in the screws. After you've determined that they fit properly you'll need to remove them to install the arms.

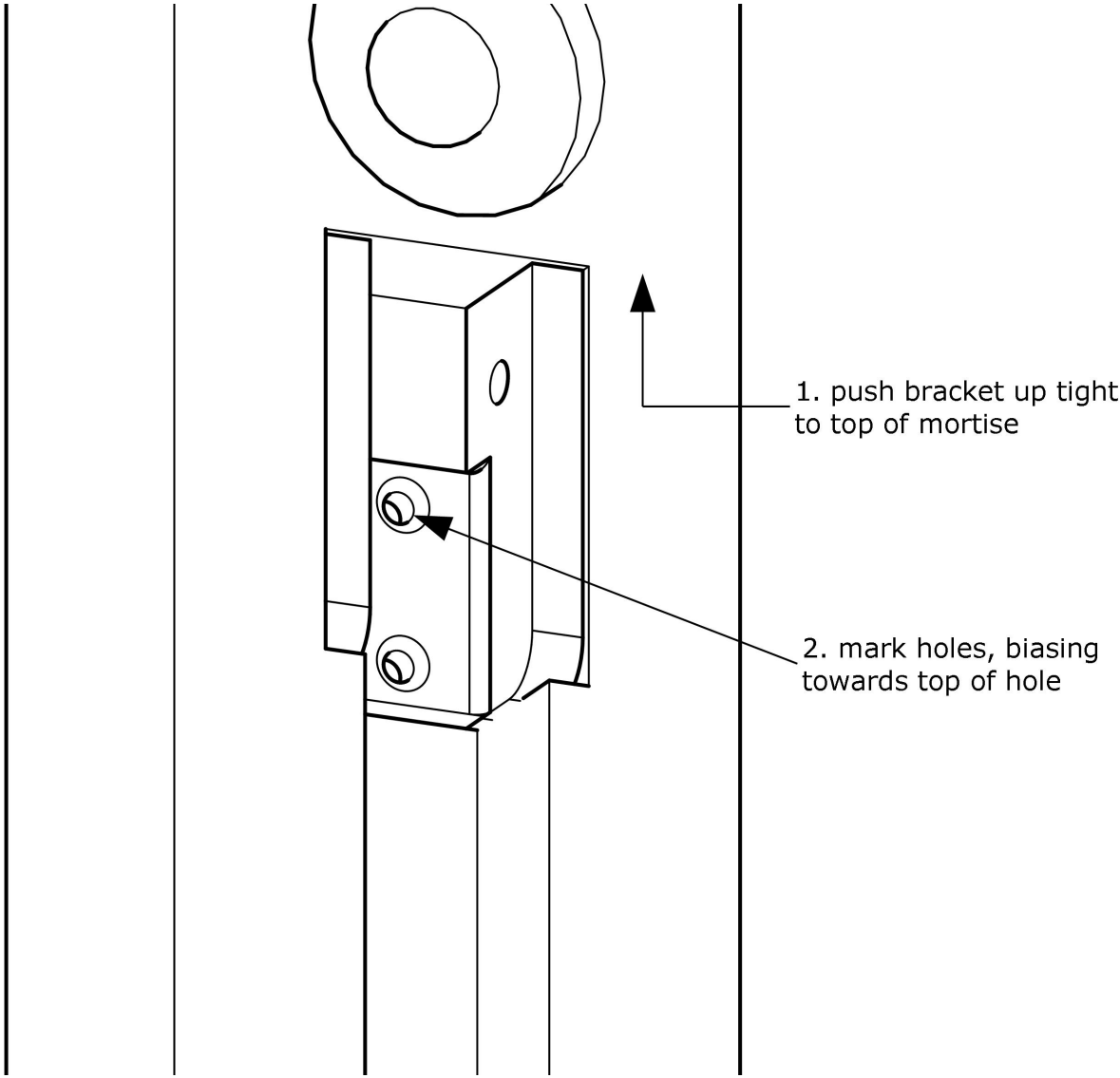

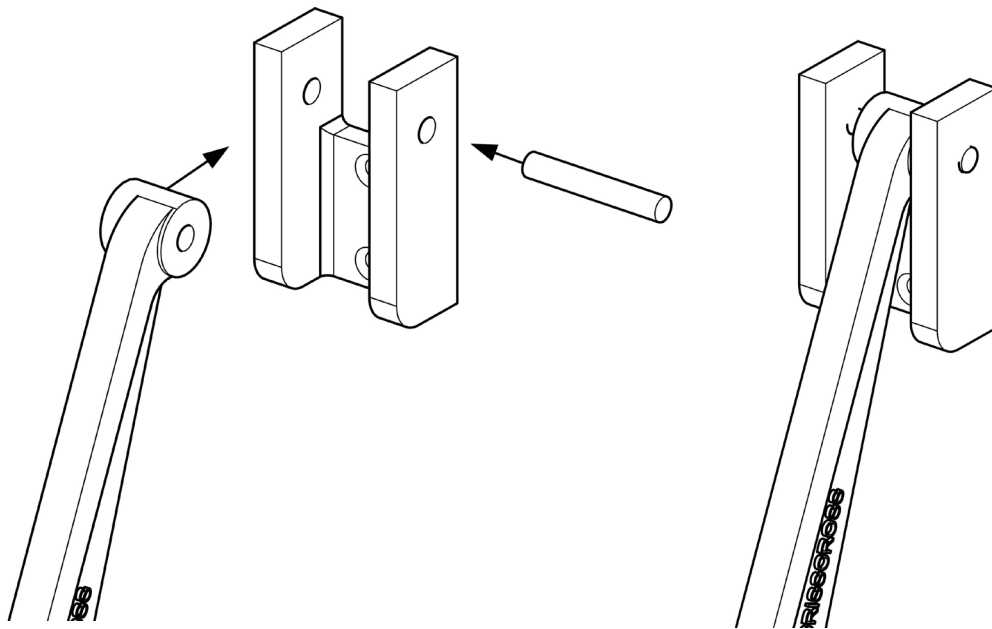

To mount the Crisscross Retro, first join each arm to the brackets with the 2-1/2" mounting pins. See the illustrations to get the orientation correct. The pins just slip in place and fit loosely and rotate with no resistance. These are held in place by the walls of the mortise, and once the bracket is installed, they are trapped in place. Now place the bracket and arm assembly in the mortise and drive the two mounting screws.

You'll need to swing the arm up and out of the way to access the mounting holes.

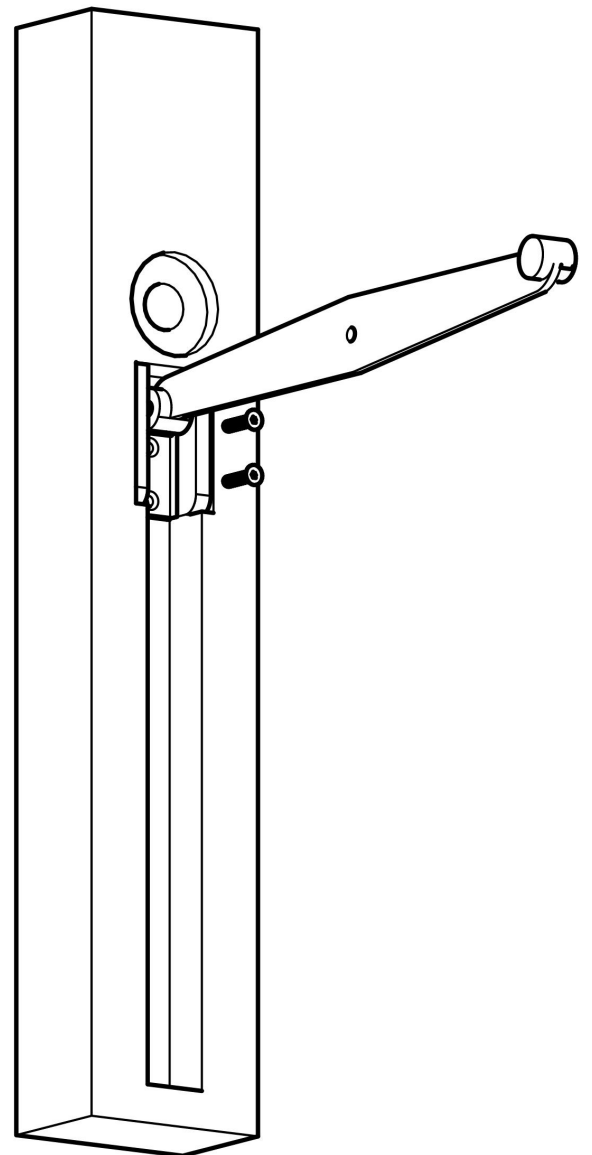

Mount both assemblies to the leg and the chop. Get ready to test the action of the assembled Crisscross Retro. If you're building a new bench and the leg isn't attached to a bench, clamp the leg in a vise or against a bench so you can test the Crisscross action in the proper upright position and with the leg held rigidly. Place the pivot pin in one of the arms with only one snap ring installed (leaving one snap ring off lets you test fit and disassemble more easily during the installation process.)

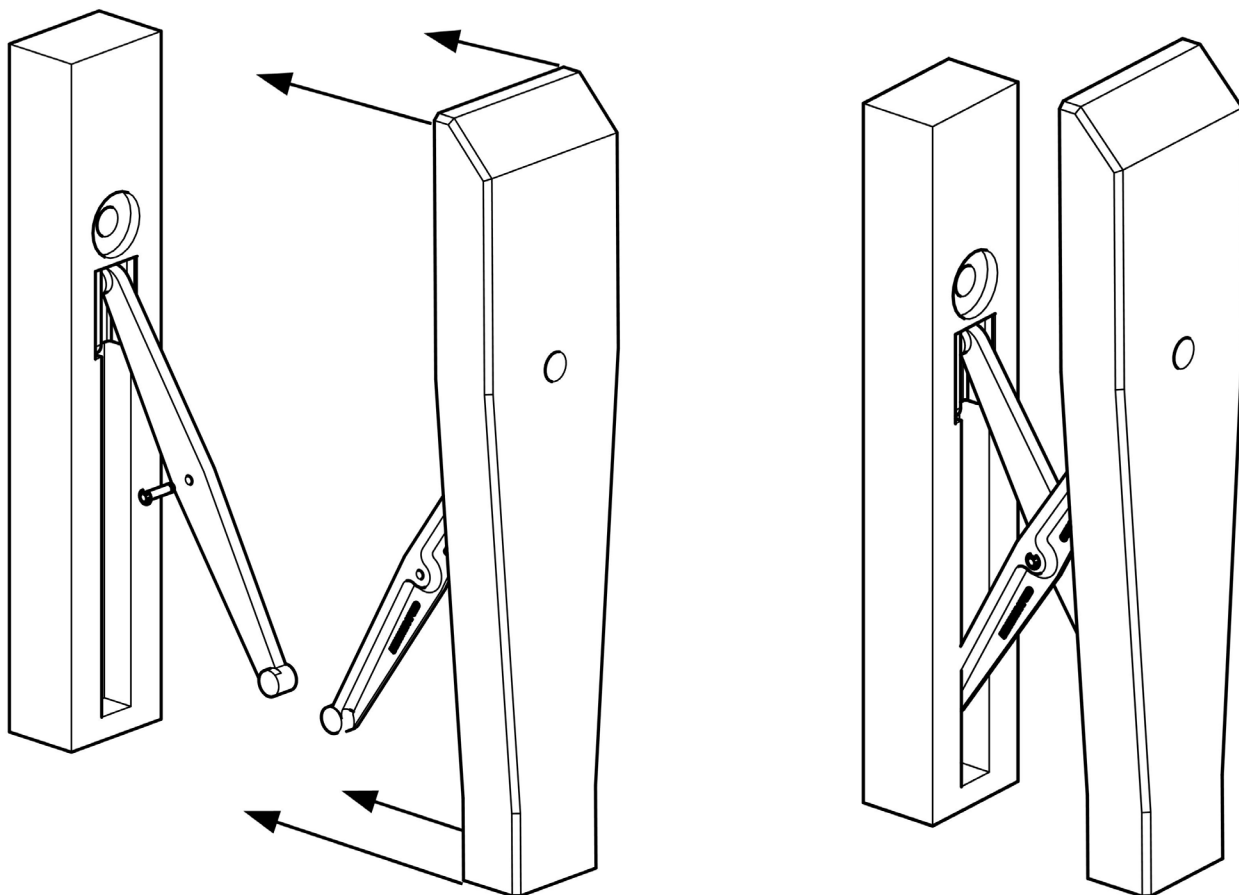

Now swing the arms together, flat back to flat back, until the central pivot pin holes align. Push the pin into the other arm. The chop should now "float" in and out quite easily as the Crisscross supports the weight of the chop. Now check the vise for proper toe-in (see "Check The Toe-In in the Solo section above.) Once the action is good, disassemble the Crisscross from the leg and chop in preparation for installing the Classic Leg Vise.

INSTALL THE CLASSIC LEG VISE SCREW ASSEMBLY

You'll need to drill two large holes to install the Classic Leg Vise. One in the chop, and one in the leg. The hole in the leg will also get a counterbore at the front to accept the acetal bushing. The locations of these holes and the sizes are illustrated at the end of the instructions on the measured drawings, as you discovered when you laid out for the Crisscross. The finished holes are illustrated below:

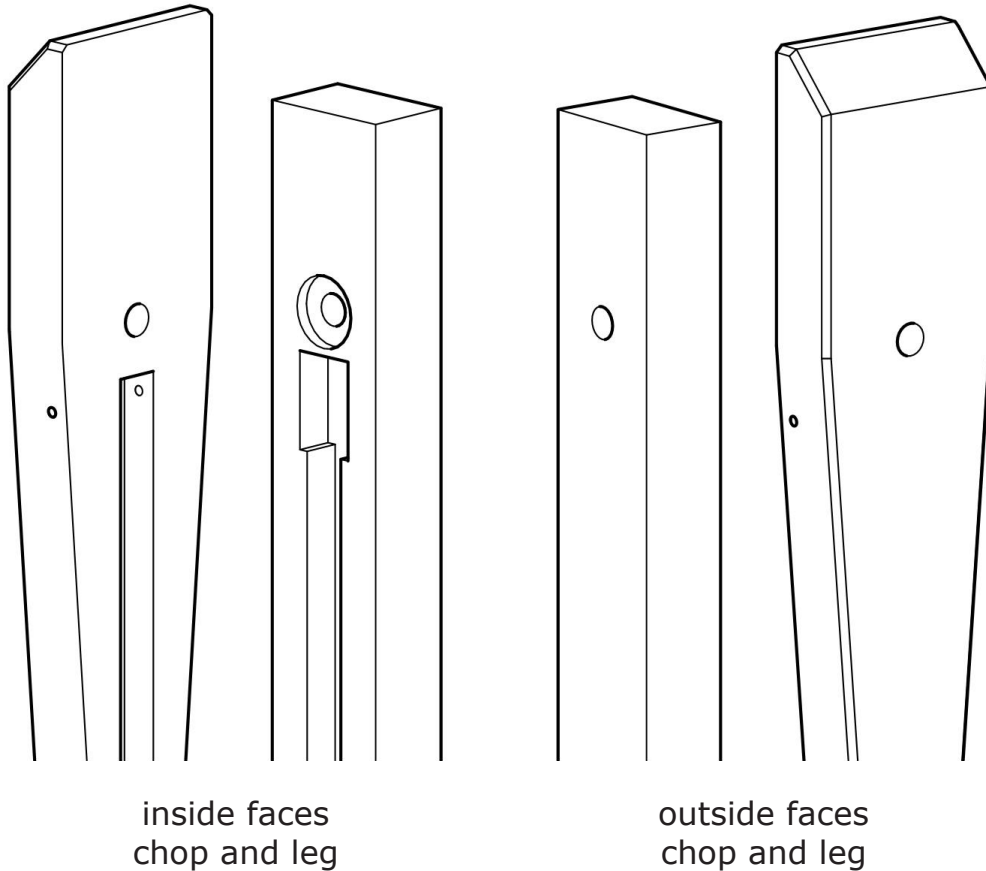

You'll want to drill these large holes from both sides of the leg and chop to prevent blowout. You can drill almost all the way through from one side, letting just the very center point of your drill bit poke through the back. Then flip the piece and finish drilling, using the tiny hole as a guide.

If you don't have a large 2-3/4" drill bit to cut the counterbore for the acetal bushing you can use a router to make the cut. You can make a circle template and use a pattern bit or template follower. The hole doesn't need to be an absolute perfect circle, you're just getting material out of the way

MOUNT THE FLANGE

Place the chop on a flat surface for this next step. To mount the screw assembly to the chop, place the screw through the hole and center the screw in the hole. To do this, first draw a horizontal and vertical line on the face of the chop, centered on the screw hole. Place the assembly in the chop and line up your assembly so the vertical line is running through the middle of the two holes in the flange. This centers the screw horizontally in the hole. For vertical positioning, shift the entire assembly towards the top of the chop within the hole until it stops, now mark the position with a pencil line at the top edge of the flange. Now shift the assembly towards the bottom until it stops and mark another line at the top edge of the flange. Now move the flange towards the top of the chop until its centered between these two marks. Make sure the flange is still centered horizontally (look through the two screw holes in the flange.) You **MUST** be certain the screw is centered in the hole and not touching the chop at all! If the screw is touching wood it will slow the vise down and not spin freely. While in this centered position, mark the two hole centers on the flange with a transfer punch, center punch or awl (see illustration.) Now remove the screw assembly by lifting it out of the hole. Drill pilot holes for the #12 screws. Choose a drill bit that matches the root diameter of the screw. If you drill too small of a pilot hole you risk breaking the screw. Once the holes are drilled, replace the screw assembly in the chop, screw the flange in place and check to see that the screw turns freely. The vise screw should not touch the walls of the hole at all, and the assembly should rotate freely.

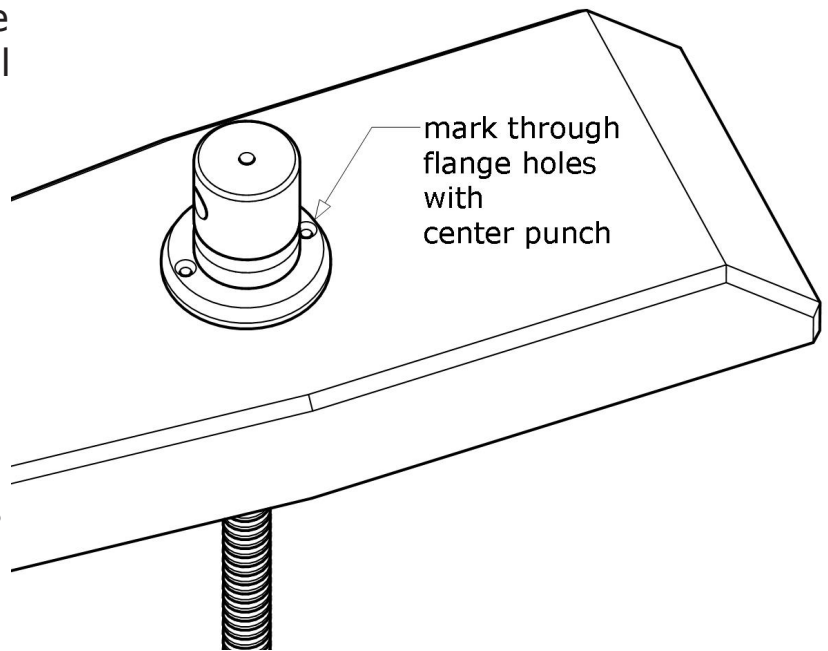

MOUNT THE NUT

Next, you need to position the vise's nut and fasten it to the bench leg. Here's how to do it. Clamp the bench leg upright and firmly to something rigid for this step. Reassemble the chop to the leg by joining the Crisscross

arms and inserting the pivot pin. If you removed the screw assembly from the chop, re-install it now. Also install the handle and spring plunger into the hub (see page 24.) The screw should now be passing completely through your bench leg. Thread the nut onto the screw until it gets close to the back of the leg. Now with one hand, press hard on the face of the hub directly in line with the center of the screw. This will push the chop

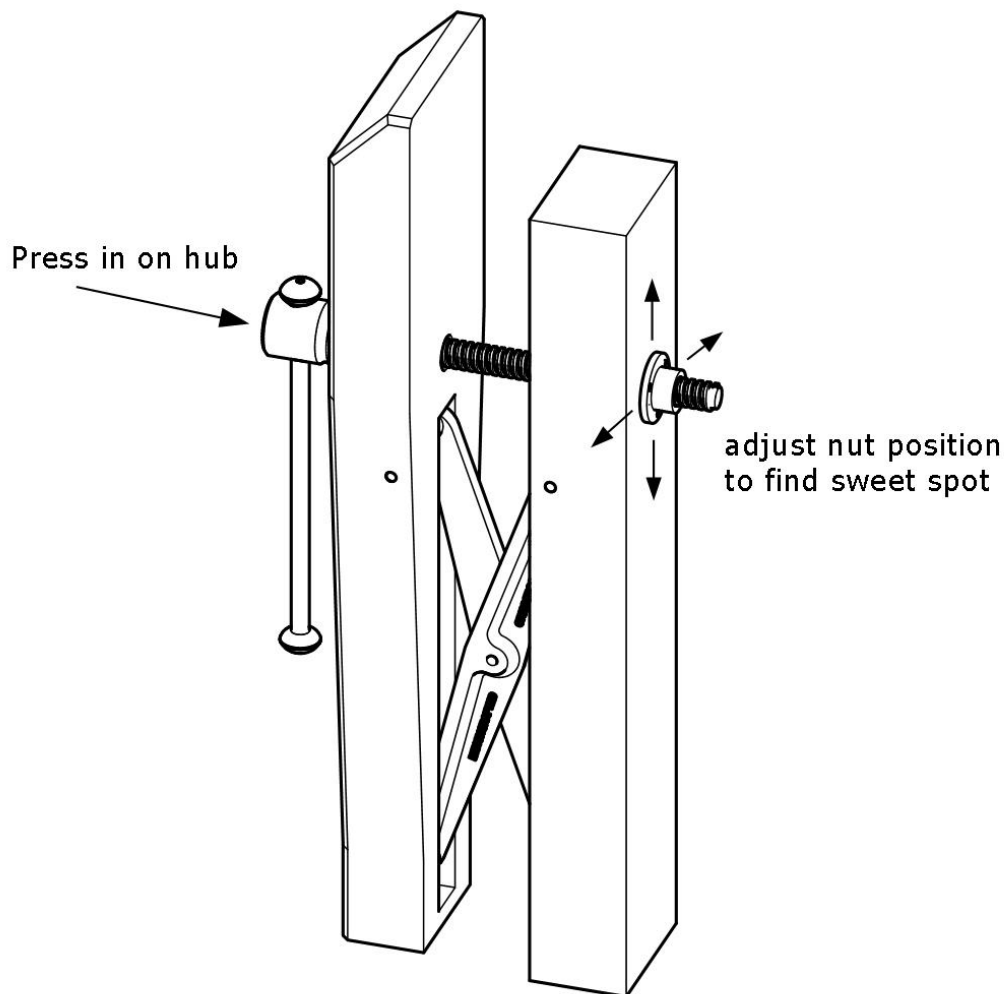

closed, forcing the inner surface of the hub to seat into the flange, positioning the screw into a closely parallel orientation with the Crisscross. As you're pushing in, you can observe the end of the screw raising up and finding its center within the leg's clearance hole. It must not touch any wood in the chop or the leg! This will slow down the action of the vise. If it touches wood, enlarge the hole until it doesn't. While still pushing in, rotate the nut as it tightens against the back of the leg with your other hand until snug. If your vise chop has a lot of toe-in your screw will point more towards the floor. Keep this in mind during the next step. While holding the nut in position firmly with one hand (pressing against the back of the leg) slowly operate the vise. Try not to move the nut. If the vise operates smoothly, close the vise carefully until the nut is again snug against the back of the leg. If it doesn't operate smoothly, try shifting the nut around to find a spot where the vise does operate smoothly. What you're doing here is finding the sweet spot where the screw is running nicely inside the nut. This will allow the vise to operate at its peak smoothness.

When you're satisfied with the nut position and action, turn the hub enough that the weight of the screw does not drop down and spoil the location of the nut, then mark the leg through the nut mounting holes for the mounting screws. Also mark the nut itself so when you install it, its in the same orientation as before (a dot at 12 o'clock is what we do.) Now remove the nut, drill the pilot holes for the three #10 wood screws, then attach the nut with the screws. Thread the vise screw back through the chop and leg and engage the nut to test the action. The vise should now work sweetly. Sometimes, depending on how much toe-in you have, or how accurately you milled your leg and chop, the nut might bind on the screw when you operate the vise. This is usually caused by the nut being out of parallel with the screw. Loosening the screws that hold the nut to the back of the leg is usually the solution. These screws do not need to cinch the nut to the leg tightly for the vise to operate properly. Leaving the nut just this side of tight (so it can float around just a tad) will allow the vise to operate very sweetly.

INSTALL THE ACETAL BUSHING

The acetal bushing, which stabilizes movement the chop, is installed next. The bushing's central hole is milled to be just a few thousandths larger than the screw's width, helping stabilize left-right movement during operation of the vise. Unthread the screw from the nut, then pull on the handwheel until the end of the screw clears the front of the leg (you don't need to separate the Crisscross arms.) Slip the bushing over the end of the screw with the counterbores facing out. Then feed the screw back through the leg and engage it in the nut a few turns. Orient the bushing so the elongated hole is vertical. See illustration.

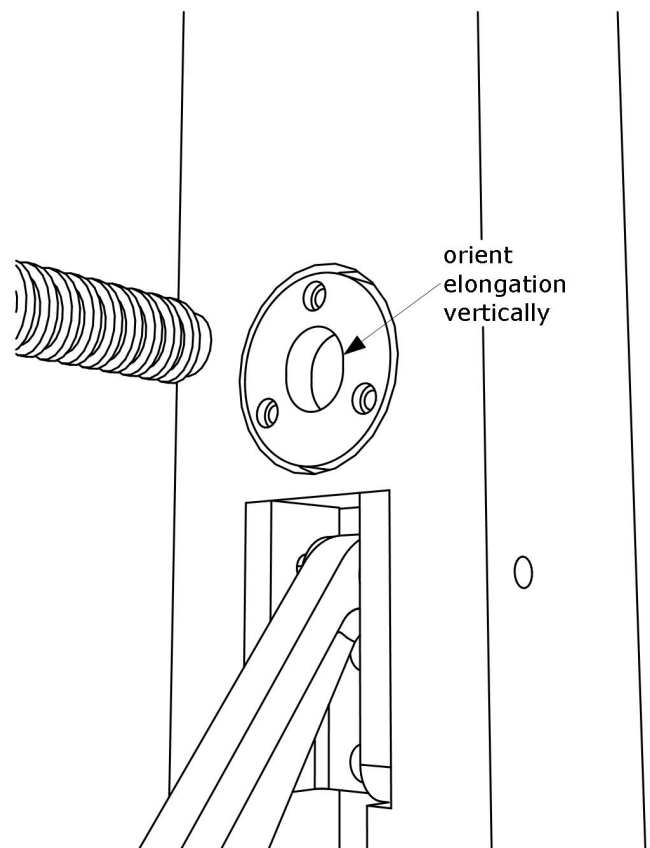

With the bushing pressed against the face of the leg, wiggle the chop left and right so you can observe the position of the bushing. You want to find the center of that left-right movement. Once you've got it, position the bushing up/down so the elongated hole is positioned equidistant from the screw on top and bottom—you want an equal gap top and bottom. Trace the perimeter of the bushing onto the face of the leg with a pencil. Unthread the screw, remove the Crisscross from the leg and then prepare to excavate the counterbore/mortise for the bushing. The bushing itself is 2-1/2" diameter, but you'll want to make the mortise larger than this, at least 2-5/8" diameter. This allows you to adjust the position of the bushing once its attached to the leg. You can drill this mortise with a Fortsner bit, circle-cutting jig and router, or with a fly cutter, followed by simply drilling or routing out the interior. The perimeter doesn't have to be a perfect circle. You don't want the bushing to be proud of the leg's surface, so make the mortise at least 9/16" deep. Reassemble the vise with the bushing place (but not yet screwed into the leg) and advance the screw a few turns into the nut. Move the chop back and forth (left and right) until the bushing is centered in the mortise, and also centered vertically. Use a transfer punch (or bradpoint bit) to mark the location of the mounting screws through the bushing while keeping the chop still. Remove the bushing, then drill pilot holes for the #8 wood screws, reinstall the bushing and attach it with the screws, but keep them a bit loose for now. Test the action of the vise with the bushing in place. The vise screw should turn freely and smoothly. Tighten one of the bushing screws and test again. Now gradually tighten the remaining screws incrementally while turning the vise screw. If you feel the vise screw getting tighter as you tighten each bushing screw, loosen the bushing screws and start again. The bushing is there to provide stability, it should not hamper the rotation of the vise's screw. It's also very important that the bottom of the mortise be flat. If it's not, the bushing will be distorted as you tighten the screws, possibly binding the main screw. If you need to remove more material from the bottom of the mortise to get it flat, do so. It doesn't matter if the bushing is slightly recessed into the leg a bit.

FINAL STEPS

Once the Classic Leg Vise is completely installed and functioning smoothly, mark and cut the chop to final length, flush with the benchtop. You can chamfer the top corner of the chop or round it over. This is also a good time to glue on the Crubber. Contact cement, hide glue, and white or yellow carpenter's glue works fine. The Crubber is an important part of the Classic Leg Vise. It provides incredible holding power with little effort. We

line all of our vises with this material, including the faces of our bench dogs. You can purchase extra Crubber at our website.

To install the handle, slip one leather washer onto the end of the handle, then thread on a mushroom nut. The washer will be on the smooth part of the handle once the nut is threaded on. Slide the handle through the hub and install the other leather washer and mushroom nut.

Thread the spring plunger into the hole in the center face of the hub. The plunger is adjustable. You can set it lightly against the sliding handle, or more firmly depending on how you like to work. The thread-locking element will last for 3-4 installation cycles, so leave it out while you install your vise. Find your favorite setting, then leave it. It won't change. If you end up wearing out the locking element, you can use some locktite to keep it in position. The v-groove milled into the center of the handle is designed to stop at the plunger so you can quickly center up and balance the handle which allows the vise to spin freely. A tighter setting makes it easier and quicker to center up the handle, but may inhibit the handle from sliding freely. There is a sweet spot that allows quick engaging with the spring plunger, and free sliding when you want. Another advantage of the spring plunger is that you can reposition the handle so it's not interfering with your work or your body. If you use the vise so the handle slides down to the hub when you release it, the mushroom nuts may eventually loosen from this action. Applying some Loctite to the mushroom nut threads will prevent them from loosening.

The screw travels 1/2" per revolution. This is twice as fast as typical metal vise screws. Subsequently, you don't need to crank down on the handle as much as you'd expect to hold your work securely.

MAINTENANCE

The black parts of the Classic Leg Vise are parkerized, a military-grade matte black finish that suggests a traditional forged look. These parts will arrive with a coating of oil, which you can wipe off with a paper towel and some mineral spirits. A thin coating of oil deepens the color. Eventually, the finish will take on a more dull look with use, gradually developing a nice patina like an old hunting rifle: dull in some spots, shinier in others where you handle it.

You should keep all the vise parts lightly oiled if your shop is not cli-

mate controlled. If you want a more vintage look, you can rub the parkerized parts with fine steel wool. This will impart more of a sheen to the parts, and give it a wonderful patinated look. The mating surfaces between the hub and flange are dished. This allows for a better bearing surface under the pressure of holding work. The parkerized finish also has a lubricating effect. You may want to lightly oil this area from time to time for the smoothest action. The Crisscross is finished with a black coating and doesn't require any additional attention. Some of the coating will wear off in use. This is normal.

We want your vise to operate perfectly and we're here to make sure you get it installed to your satisfaction.

If you need assistance, write us at technical@benchcrafted.com

ADDENDUM

Tapping Holes In Wood For Machine Screws

Aside from the typical woodworking tools required to build the wood components of the vise and install it, you'll need a machine screw tap to install the machine screws in the Retro brackets. Many of you will already have this tap, and for those who don't, you'll be able to pick one up at any hardware store or home center. Mail order suppliers like Enco or McMaster will also have taps. Taps are inexpensive.

To attach the brackets you'll need a 5/16-18 bottoming tap. Standard plug taps will work fine, but bottoming taps (they cut threads almost to the bottom of a hole) will require a shallower hole. This is important for the Retro, especially in the chop which may have less wood thickness available for tapping. Pilot hole size for 5/16-18 is 1/4", or a tad less like 15/64 if you have it.

The holding power of machine screws in wood is about the same as using a threaded insert, and you don't have to buy the inserts. It's also a great technique for making jigs and knock-down joints. Once you drill the pilot hole (use a drill press for accuracy if possible) chuck the tap in a small, cordless, variable-speed driver with the torque set for driving screws (the slower setting). Hold the drill perpendicular to the surface and without pushing on the drill (just support its weight while keeping it square) press the trigger and let the tap feed itself into the hole slowly. It helps to cut a small countersink in the pilot hole to help get the tap started.

When you feel the tap tighten up a bit and you've reached the depth of threads you're after, release the trigger. Switch the drill into reverse and press the trigger without pulling on the drill. Let the tap thread itself out of the hole slowly. It's important to go slow and feel how the tap is working. If you go too fast you risk binding the tap. At that point the tap becomes a drill bit and you just end up making a larger hole. If you're new to this, practice on some scrap first. You can also tap the holes by hand, but once you get the hang of using the driver it makes tapping quick and easy.

**Dimension X will vary depending on your bench height*

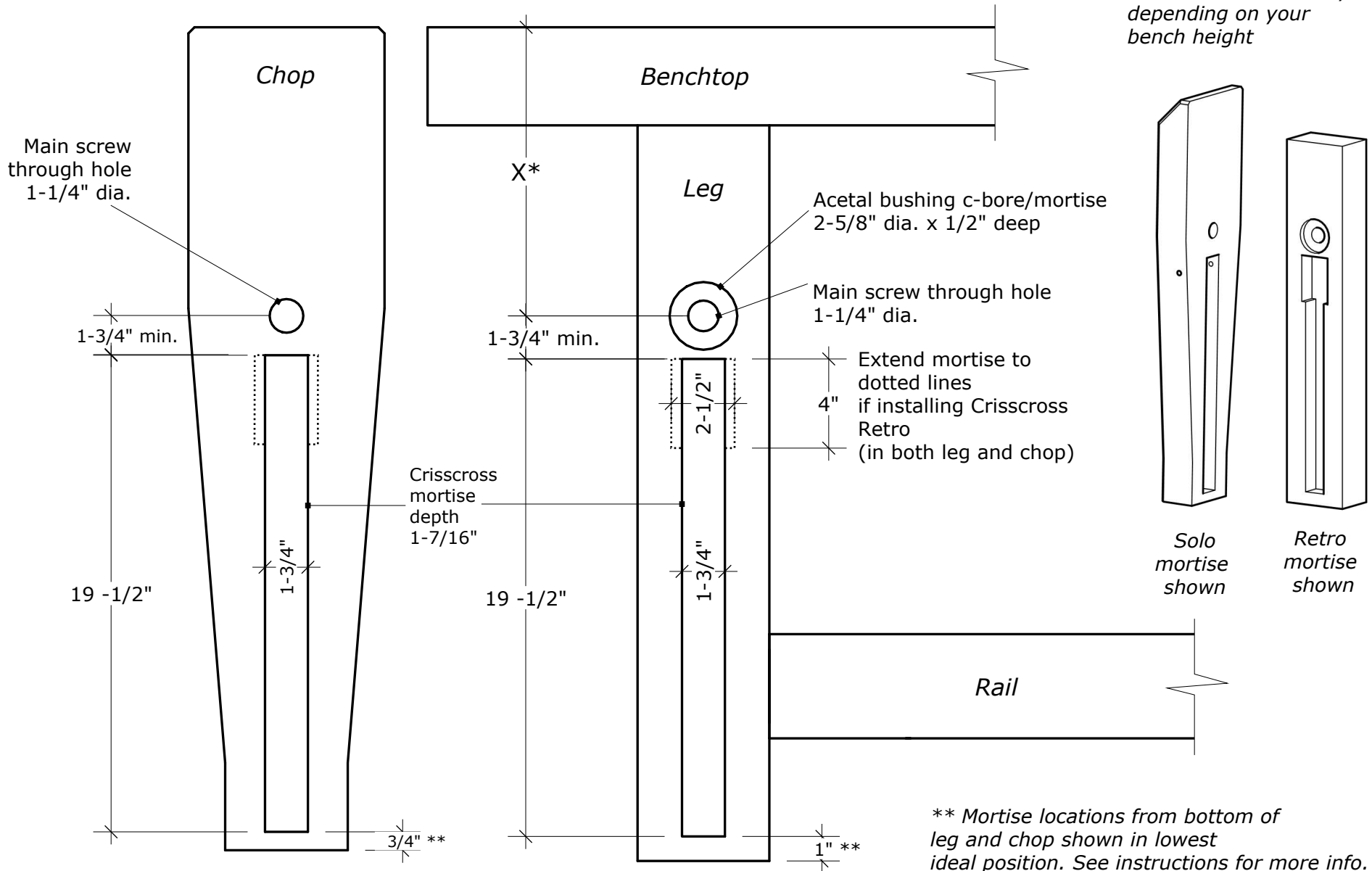

Crisscross mortise depth is 1-7/16" deep in both the chop and the leg.

**** Mortise locations from bottom of leg and chop shown in lowest ideal position. See instructions for more info.**

Classic Leg Vise Crisscross Solo and Retro		Mortise and screw hole layout		
Copyright 2021 Benchcrafted No unauthorized duplication without permission.		Scale: not to scale	Page: Version: Dec '21	

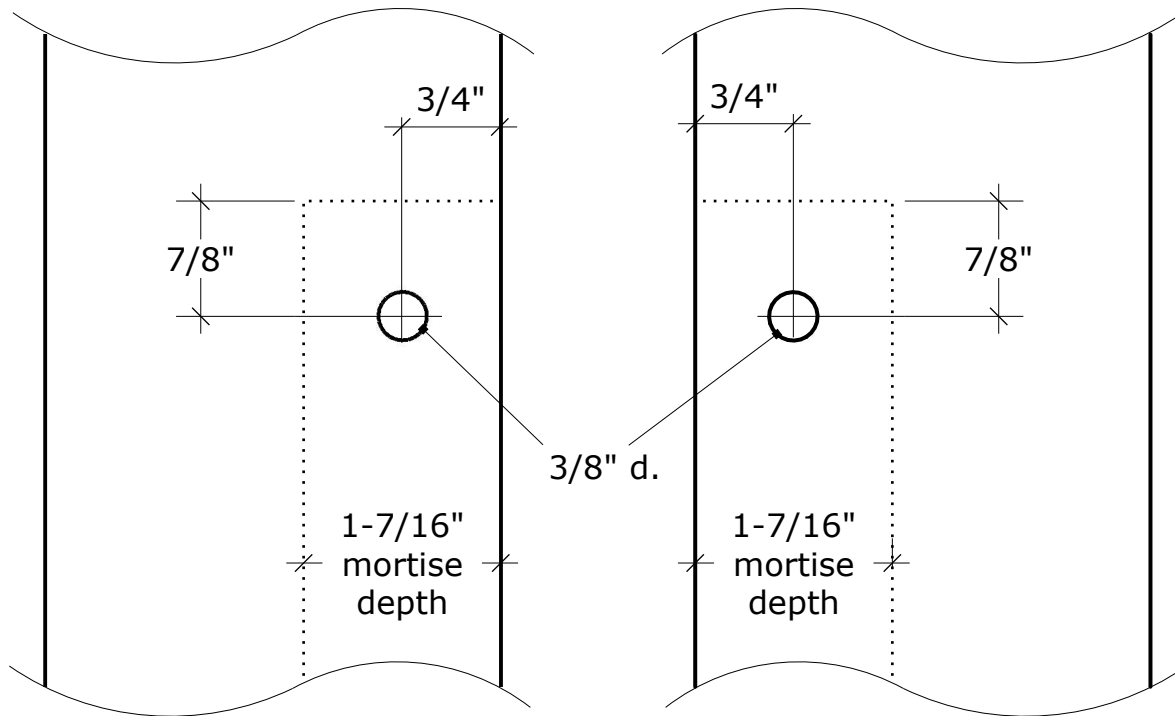

Side of Chop

Side of Leg

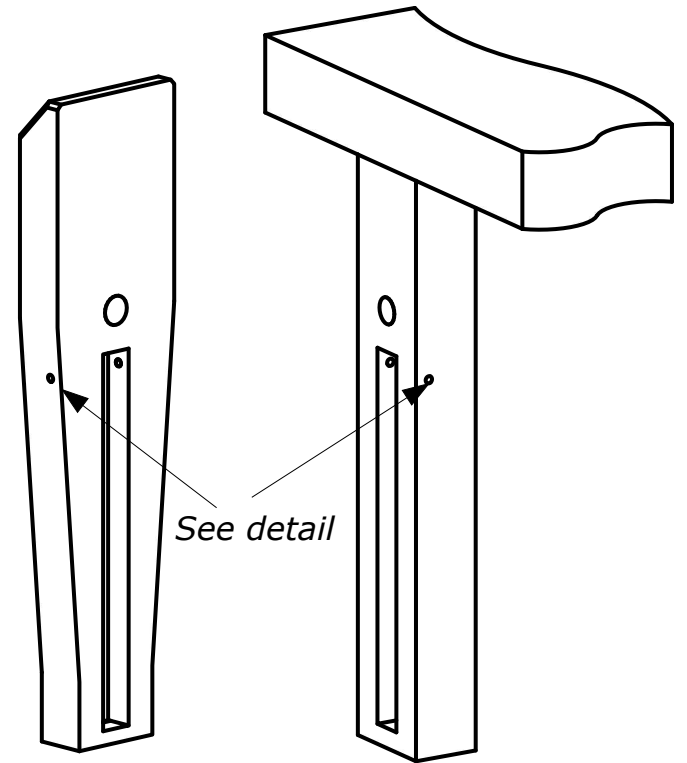

Detail

Crisscross Solo		Mounting Pin Location		
Copyright 2021 Benchcrafted No unauthorized duplication without permission.		Scale: nts	Page:	

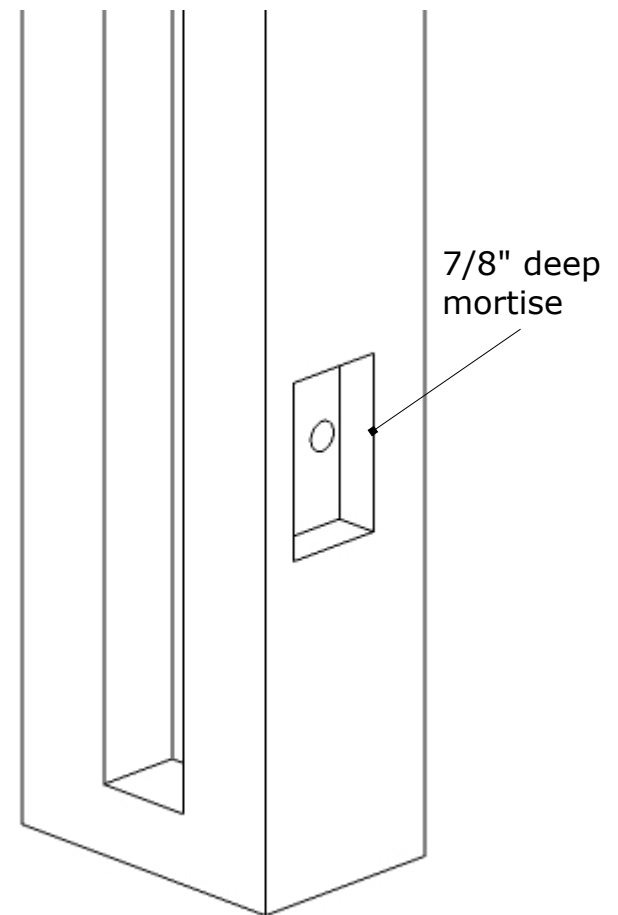
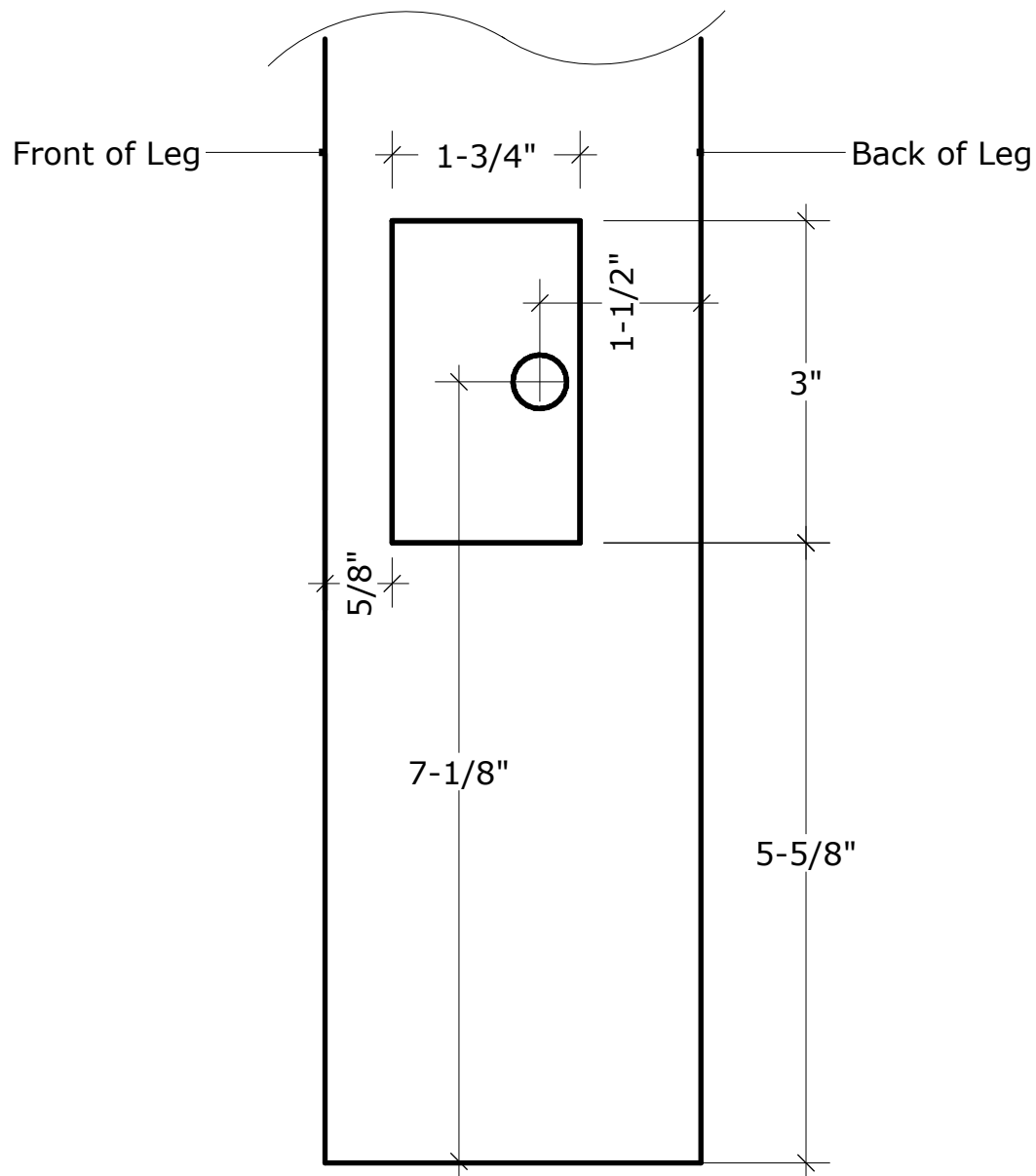

*Leg Vise leg shown (w/ Crisscross mortise)
Cut mirror-image rail mortise on
opposite front leg.*

This template is taken from our Split Top Roubo Bench plans and represents a suggested way of joining a front rail to a leg in a Roubo-style bench to accommodate the Crisscross and our Barrel Nut hardware. Your bench configuration may be different.

Crisscross		Front Rail Mortise		
Copyright 2021 Benchcrafted No unauthorized duplication without permission.		<i>Scale:</i> <i>none</i>	<i>Page:</i> <i>1:1</i>	

Cut on both ends of front rail.

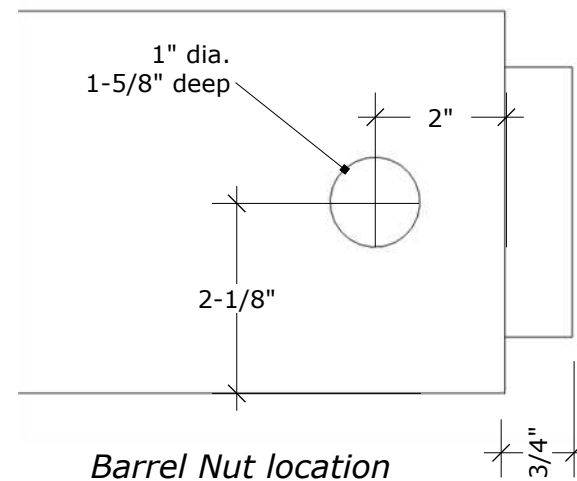
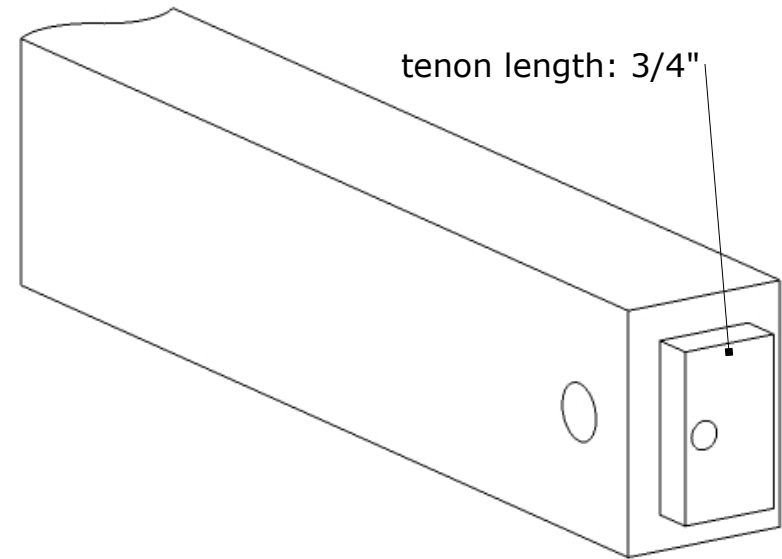
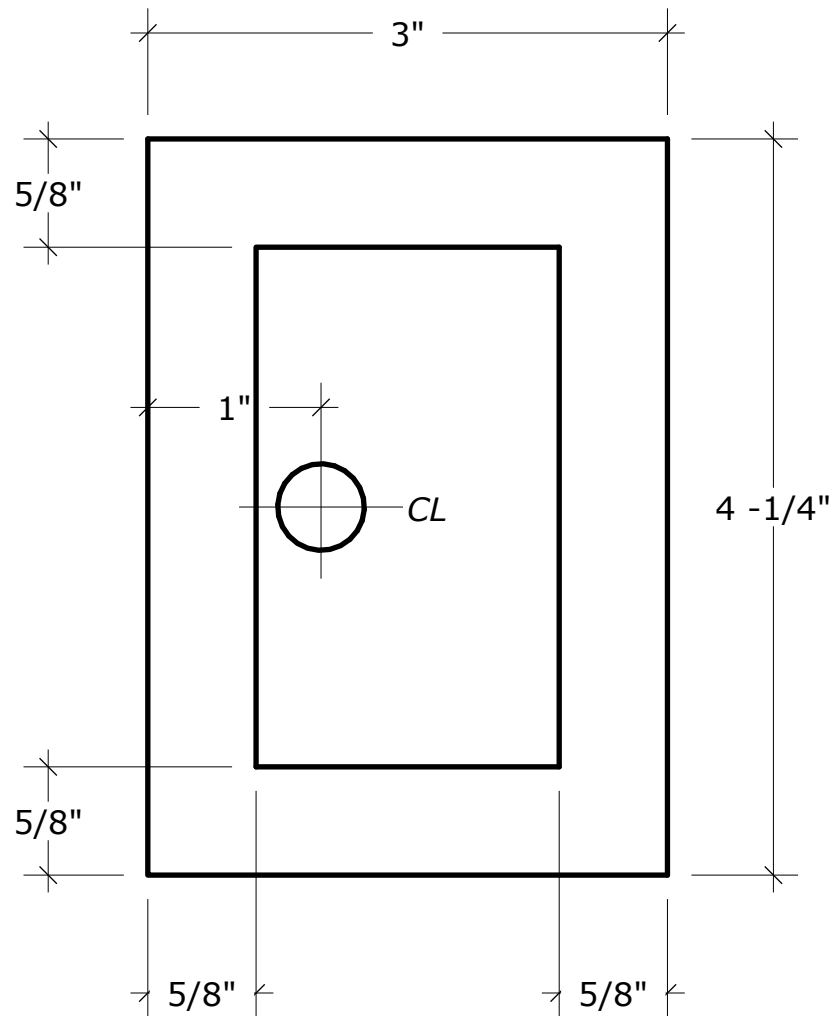

This template is taken from our Split Top Roubo Bench plans and represents a suggested way of joining a front rail to a leg in a Roubo-style bench to accommodate the Crisscross and our Barrel Nut hardware. Your bench configuration may be different.

Crisscross	Front Rail Tenon			
<small>Copyright 2021 Benchcrafted No unauthorized duplication without permission.</small>	<small>Scale: none</small>	<small>Page:</small>	<small>Version: Dec. '21</small>	

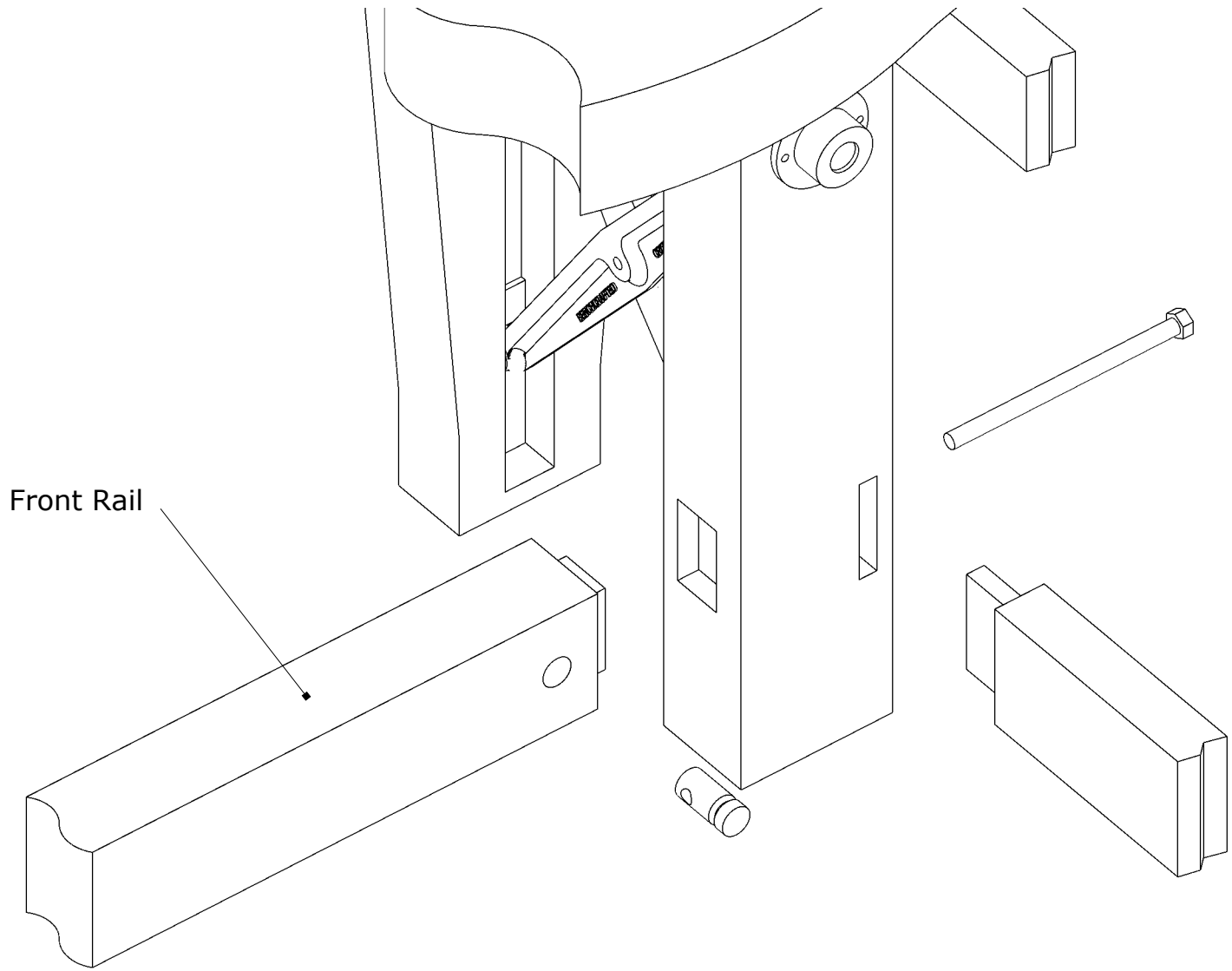

Front Rail

3d illustration of joinery outlined above

Crisscross	Vise Leg Joinery			
Copyright 2021 Benchcrafted No unauthorized duplication without permission.	Scale:	Page:	Version:	

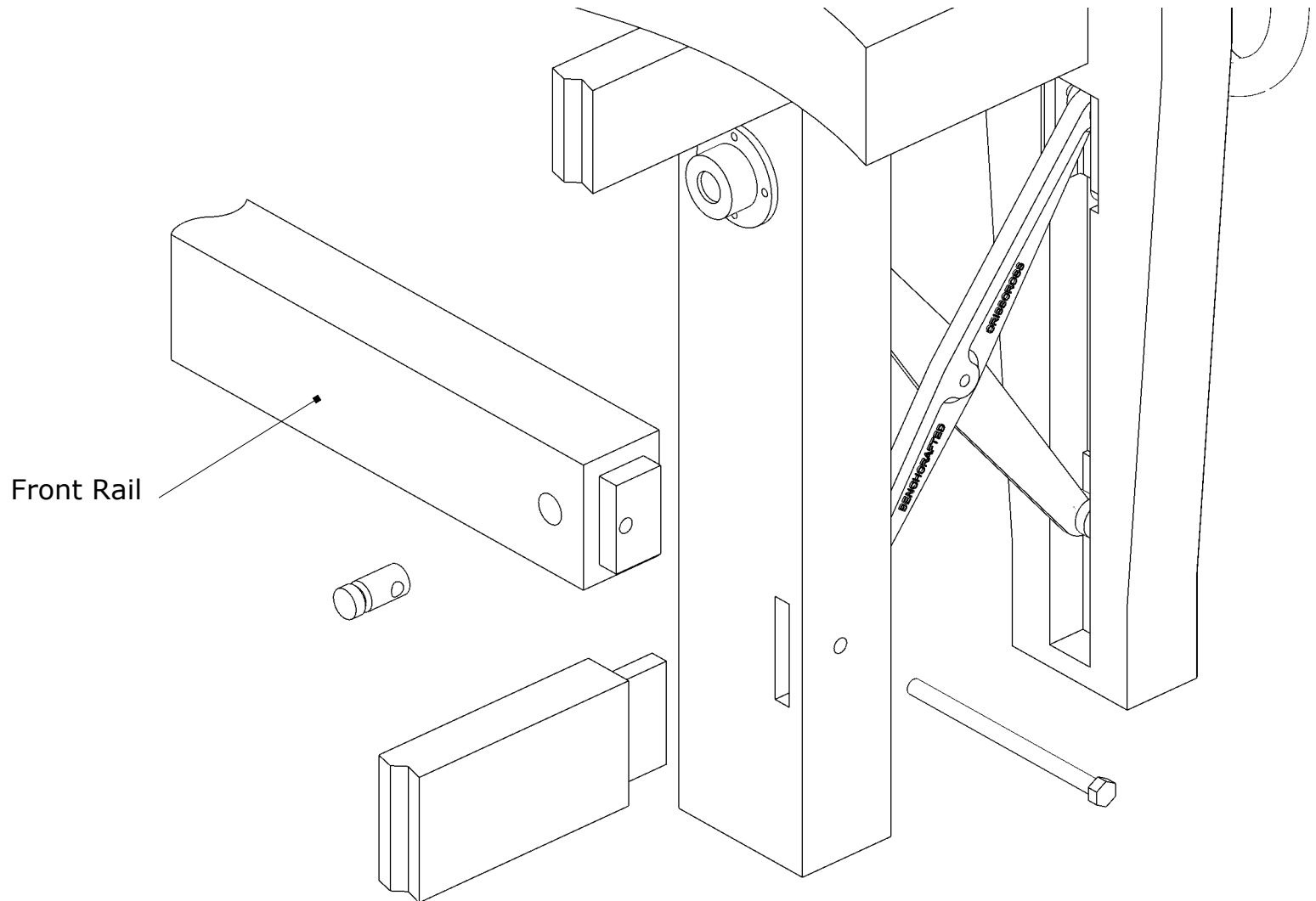

3d illustration of joinery outlined above

Crisscross		Vise Leg Joinery 2		
<small>Copyright 2021 Benchcrafted No unauthorized duplication without permission.</small>		Scale:	Page:	

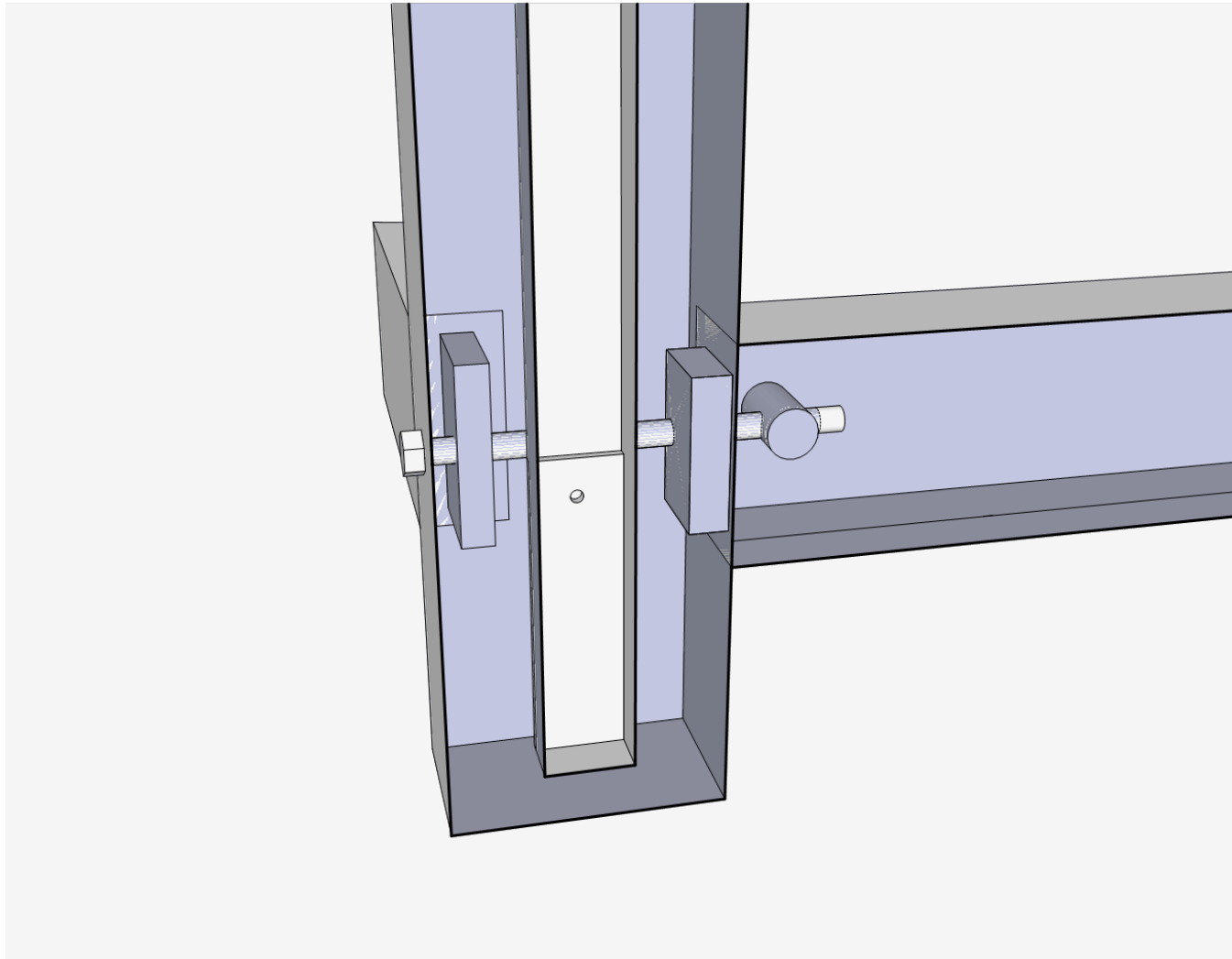



Illustration of how the bolt that engages the Benchcrafted Barrel Nut passes behind the Crisscross mortise in our Split Top Roubo workbench.

Crisscross	Leg Joinery Cross Section			
<i>Copyright 2021 Benchcrafted No unauthorized duplication without permission.</i>	Scale: nts	Page:	Version: Dec. '21	